



# Memory Packings

**E**lring memory packings are single-acting sealing elements with excellent sliding properties. They are used primarily for sealing reciprocating pistons and rods as well as for rotary and swiveling applications. The one-piece seal is manufactured from the high-strength fluoroplastic, PTFE or PE-UHMW, with its memory effect resulting from a special manufacturing technique. The memory effect allows the required contact pressure to be achieved without an additional spring element.

## **Benefits**

- Extremely low friction, constant across a wide temperature range
- Outstanding dry-running characteristics
- No stick-slip effects even at low sliding speeds
- Extremely low breakaway forces even after prolonged downtimes
- High chemical and thermal resistance
- No volumetric changes by swelling or shrinkage
- Compact design
- Very good cost/benefit ratio
- Suitable for sterilizing
- Easy to flush
- Dimensions from 3 mm to 140 mm available
- Special dimensions available on request

This means that preload can be kept very low, thus providing the Elring memory packing with outstanding friction properties. In conjunction with the special PTFE compounds HS 21059 and HS 21029 developed for this product this translates into low wear of the sealing lip and thus long service life with low breakaway and displacement forces. Since the seal is installed with the open side facing toward the higher system pressure, the sealing effect increases with rising pressure.

Elring memory packings are used in any application placing particularly high demands on the friction behavior of the seal.



# Fields of Application

## Application Examples



### **Pneumatics**

*Cylinder seal with low displacement force for stick-slip-free operation.*

*Memory packings are used in a wide range of industrial applications:*

- Automotive industry, e.g. in headlight washer systems, small compressors for pneumatic suspensions, ride leveling systems, vibration dampers
- General manufacturing and mechanical engineering, e.g. valves and solenoid valves
- Pneumatics, e.g. in cylinders and other pneumatic components
- Compressors and vacuum pumps, e.g. oil-free compressors/applications
- Food processing industry, e.g. metering devices and packaging/filling equipment
- Medical and pharmaceutical industry, e.g. in dental technology piston compressors
- Tank system engineering, e.g. vacuum pumps for fuel vapor suction systems
- Painting technology, e.g. in paint valves

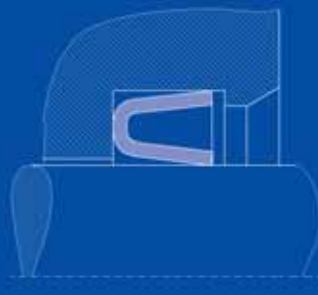
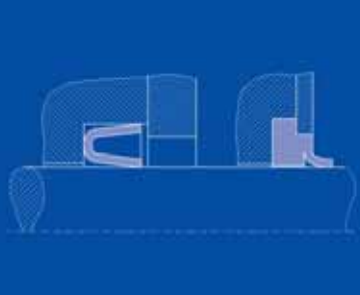

**Compressors and Vacuum Pumps**

Wobble piston compressor with cup seal serving as a piston seal in non-lubricated operation (oil-free application).

**Food Processing Industry**

Rod seal used in valves for bottling plants. With minimum clearance space and good flushing properties (aseptic applications).

**Painting Technology**

Valve needle seal for paint valves in automotive painting lines.

**Seal Design and Action Principle**

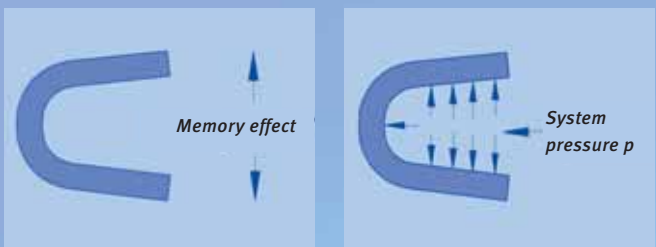
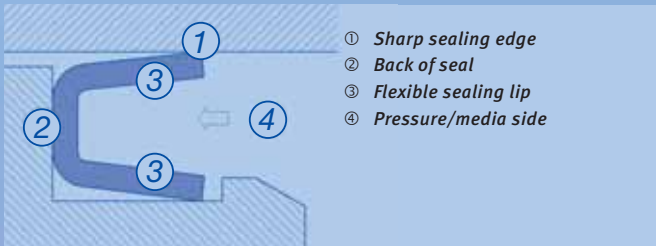

The action principle of all seal types and shapes is identical. The seals differ merely in terms of their geometries and applications. The sealing effect is achieved by the inherent preload of the plastic casing (memory effect of the compound). The radial contact pressures are sufficient to effectively seal a pressureless application. In the event of additional system pressure the contact pressure forces will rise along with the total sealing pressure.

## Standard Type EMS



**EMS – Piston and Rod Seal;  
and as Shaft Seal**

### Operating Limits<sup>(1)</sup>

T = -40 °C to +220 °C

p = up to 20 bar

v = 15 m/s ⇄

v = 1.0 m/s ↻

### Stock Range, Standard Dimensions, Basic Type: EMS

Ordering example: EMS – 12 x 6 x 3.6 – HS 21029

EMS = Type

12 = Hole Ø

6 = Rod Ø

3.6 = Groove width

HS 21029 = Standard compound PTFE special compound HS 21029,  
the advanced, second-generation compound is HS 21059.

To find the compound combinations best suiting the  
respective applications see compound table   
pages 60 – 62.

| Hole Ø<br>A <sup>H9</sup> | Rod Ø<br>B <sub>f7</sub> | Groove Depth<br>T | Groove Width<br>G <sup>+0.2</sup> | Part-No. |
|---------------------------|--------------------------|-------------------|-----------------------------------|----------|
| 12                        | 6                        | 3                 | 3.6                               | 386.480  |
| 13                        | 7                        | 3                 | 3.6                               | 206.070  |
| 14                        | 8                        | 3                 | 3.6                               | 403.687  |
| 16                        | 10                       | 3                 | 3.6                               | 785.881  |
| 18                        | 12                       | 3                 | 3.6                               | 785.903  |
| 19                        | 13                       | 3                 | 3.6                               | 210.030  |
| 20                        | 14                       | 3                 | 3.6                               | 785.911  |
| 22                        | 16                       | 3                 | 3.6                               | 785.938  |
| 24                        | 18                       | 3                 | 3.6                               | 786.012  |
| 25                        | 19                       | 3                 | 3.6                               | 783.765  |
| 26                        | 20                       | 3                 | 3.6                               | 092.100  |
| 28                        | 20                       | 4                 | 5.0                               | 785.954  |
| 30                        | 22                       | 4                 | 5.0                               | 786.020  |
| 32                        | 24                       | 4                 | 5.0                               | 785.962  |
| 33                        | 25                       | 4                 | 5.0                               | 786.039  |
| 36                        | 28                       | 4                 | 5.0                               | 786.047  |
| 38                        | 30                       | 4                 | 5.0                               | 787.515  |
| 40                        | 32                       | 4                 | 5.0                               | 785.970  |
| 44                        | 36                       | 4                 | 5.0                               | 786.055  |
| 50                        | 40                       | 5                 | 6.3                               | 785.989  |
| 55                        | 45                       | 5                 | 6.3                               | 403.970  |
| 60                        | 50                       | 5                 | 6.3                               | 785.997  |
| 63                        | 53                       | 5                 | 6.3                               | 786.004  |
| 66                        | 56                       | 5                 | 6.3                               | 780.960  |
| 70                        | 60                       | 5                 | 6.3                               | 090.980  |
| 73                        | 63                       | 5                 | 6.3                               | 840.327  |
| 80                        | 70                       | 5                 | 6.3                               | 786.063  |
| 100                       | 88                       | 6                 | 7.5                               | 786.071  |
| 112                       | 100                      | 6                 | 7.5                               | 840.173* |
| 125                       | 113                      | 6                 | 7.5                               | 385.743* |

\* Dimensions not in stock. Tools are available. Deliveries on request.  
Special dimensions and other compounds available on request.

# Installation Dimensions

## Rod Seal

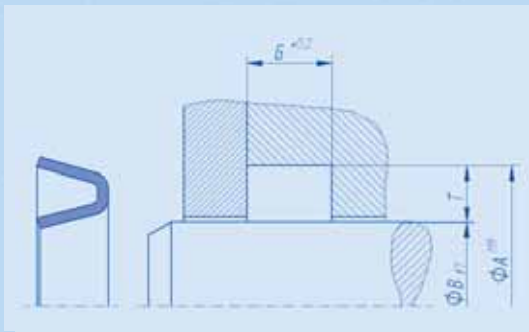

| Rod $\Phi$<br>$B_{H7}$ | Groove Depth<br>$T$ | Groove Width<br>$G^{+0.2}$ |
|------------------------|---------------------|----------------------------|
| 6 – 20                 | 3                   | 3.6                        |
| 20 – 40                | 4                   | 5.0                        |
| 40 – 88                | 5                   | 6.3                        |
| 88 – 113               | 6                   | 7.5                        |

## Piston Seal

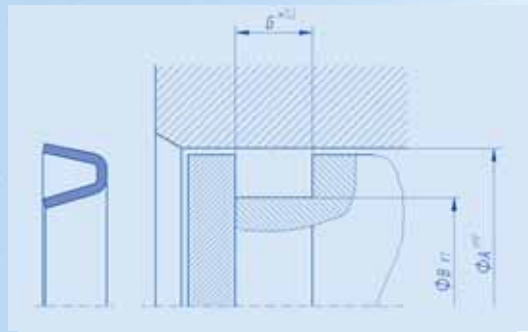

| Cylinder $\Phi$<br>$B_{H7}$ | Groove Depth<br>$T$ | Groove Width<br>$G^{+0.2}$ |
|-----------------------------|---------------------|----------------------------|
| 12 – 28                     | 3                   | 3.6                        |
| 28 – 50                     | 4                   | 5.0                        |
| 50 – 100                    | 5                   | 6.3                        |
| 100 – 125                   | 6                   | 7.5                        |



## Standard Types EMT | EMTX | EMH | EMHX (without stock range)

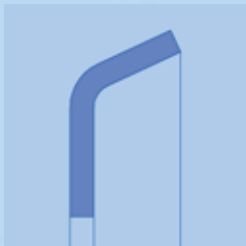

### EMT – Piston Seal

Cup packing used as piston seal.



### EMH – Rod Seal | Wiper | Shaft Seal

Cap packing used as rod seal/wiper as well as shaft seal.



### EMTX – Piston Seal

Cup packing, with integrated guide, used as piston seal.



### EMHX – Rod Seal | Wiper | Shaft Seal

Cap packing with integrated guide.

## Special Versions

For certain application requirements different versions of ready-/easy-to-assemble **complete solutions** are available as well.

### **Benefits:**

- One-piece piston
- Replaces metal piston by plastic piston
- Ready-/easy-to assemble versions offering favorable cost-benefit ratio
- No damage to seals during assembly/installation
- Complete package solutions, including seal and integrated guide, available

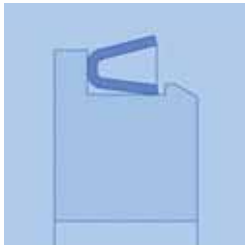

### **Complete Piston with Standard Memory Packing EMS**

Single-acting; piston can be made from aluminum, plastic or steel.

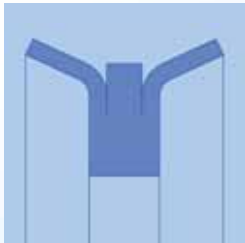

### **Complete Piston**

Double-acting with guide.

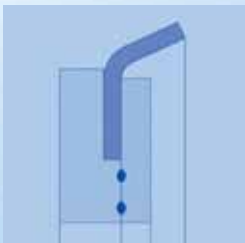

### **Complete Piston with Memory Cup Packing in Plastic Piston – Ultra-Sonic-Welded**

PA or POM plastic piston.



### **Sealing Bush as Rod and Guide Bush**

Double-acting.

## Technical Details

The memory effect is dependent on a number of different influencing factors, such as manufacturing parameters, tool/mold design, sealing compound, etc.

When it comes to designing a memory packing, you can trust us to draw on years of experience. All you need to do is to provide us with your technical operating conditions. To do so, simply complete our technical questionnaire at the end of the catalog.

### **Displacement Force**<sup>(2)</sup>

This diagram shows the low displacement force of a memory packing compared to spring-energized seals and a hydraulic seal, a so-called O-ring-pre-loaded PTFE stepped ring (SRI). The low displacement force results from the low preload of the memory packing. It offers extremely favorable friction behavior.

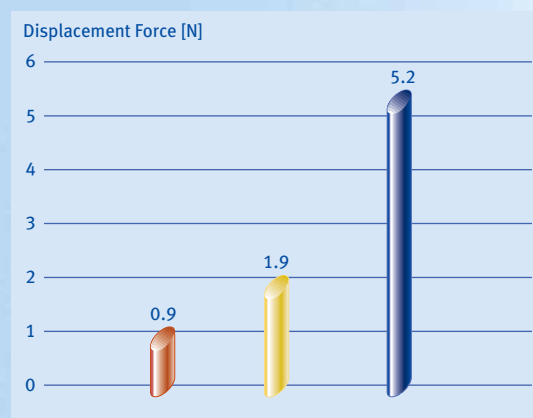

- *Memory packing type EMS*
- *Spring-energized seal type URI*
- *Stepped seal SRI with O-ring*

### **Test Conditions:**

Hydraulic cylinder rod  $\varnothing$  11 mm,  
hard-chromium-plated, Rz 0.2  $\mu\text{m}$ ,  
 $v = 60$  mm/min, pressureless,  
oil-lubricated, room temperature



# Design and Fitting Instructions (see Spring-Energized Seals chapter, page 30)

## Rod Seal

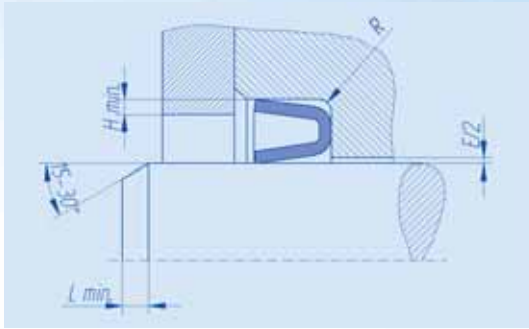

Assembly with split groove.

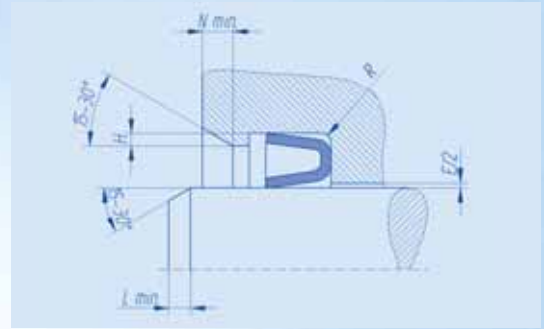

Assembly with semi-closed groove (snap-in assembly).

## Snap-in assembly

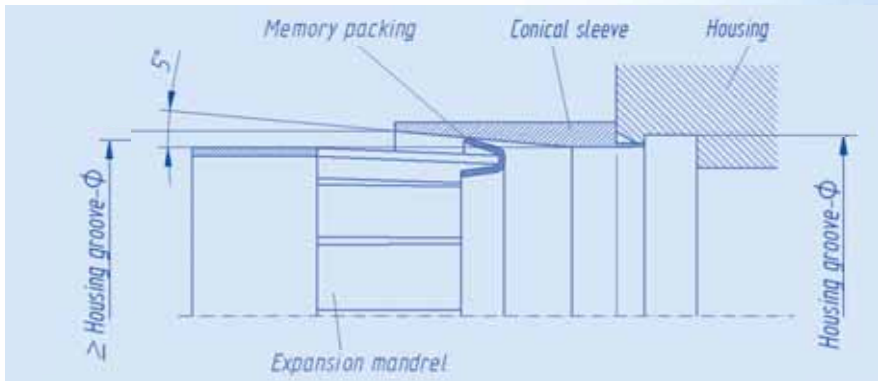

| Nominal Cross-Section <sup>(a)</sup><br>T x G | Lead-in Chamfer<br>L <sub>min</sub> at |           | Retainer<br>H or H <sub>min</sub> | Fitting Taper<br>N <sub>min</sub> at |           | Radius<br>R | Radial Clearance<br>max E/2 |
|---|--|-----------|-----------------------------------|--------------------------------------|-----------|-------------|-----------------------------|
|   | 15° Phase                              | 30° Phase |                                   | 15° Phase                            | 30° Phase |             |                             |
| 3 x 3.6                                       | 4.8                                    | 2.3       | 0.4                               | 3.7                                  | 1.7       | 0.25        | 0.05                        |
| 4 x 5.0                                       | 4.8                                    | 2.3       | 0.5                               | 4.5                                  | 2.1       | 0.25        | 0.07                        |
| 5 x 6.3                                       | 4.8                                    | 2.3       | 0.6                               | 4.5                                  | 2.1       | 0.30        | 0.08                        |
| 6 x 7.5                                       | 4.8                                    | 2.3       | 0.7                               | 5.2                                  | 2.4       | 0.30        | 0.10                        |

## Piston Seal

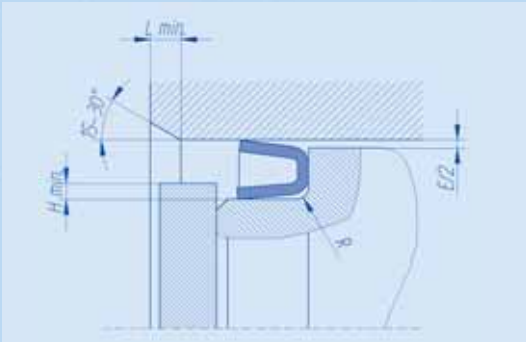

Assembly with split groove.

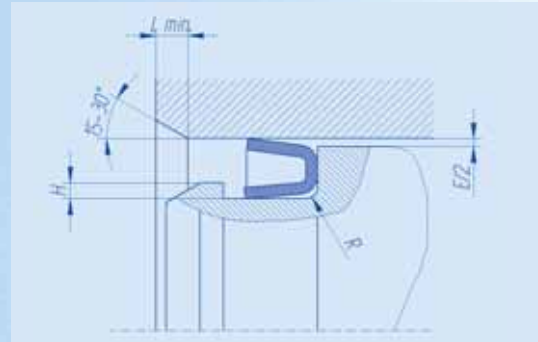

Assembly with semi-closed groove (snap-in assembly).



## Snap-in assembly

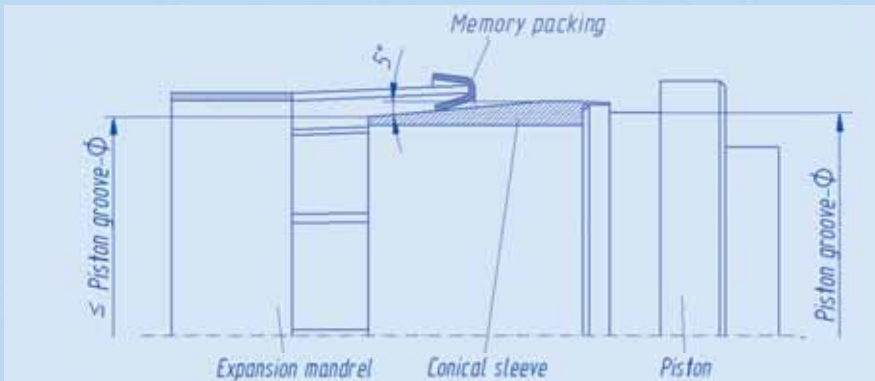

| Nominal Cross-Section <sup>(6)</sup><br>T x G | Lead-in Chamfer<br>L <sub>min</sub> at |           | Retainer<br>H or H <sub>min</sub> | Fitting Taper<br>N <sub>min</sub> at |           | Radius<br>R | Radial Clearance<br>max E/2 |
|---|--|-----------|-----------------------------------|--------------------------------------|-----------|-------------|-----------------------------|
|   | 15° Phase                              | 30° Phase |                                   | 15° Phase                            | 30° Phase |             |                             |
| 3 x 3.6                                       | 4.8                                    | 2.3       | 0.4                               | 3.7                                  | 1.7       | 0.25        | 0.05                        |
| 4 x 5.0                                       | 4.8                                    | 2.3       | 0.5                               | 4.5                                  | 2.1       | 0.25        | 0.07                        |
| 5 x 6.3                                       | 4.8                                    | 2.3       | 0.6                               | 4.5                                  | 2.1       | 0.30        | 0.08                        |
| 6 x 7.5                                       | 4.8                                    | 2.3       | 0.7                               | 5.2                                  | 2.4       | 0.30        | 0.10                        |

## Surface Quality

See Spring-Energized Seals chapter.

## Storage Instructions

See Spring-Energized Seals chapter.