

# Spring-Energized Seals



Spring-energized seals are single-acting sealing elements primarily used for sealing reciprocating pistons and rods. Other uses include rotary, swiveling and static applications.

*The seal consists of two components:*

- an outer sealing element made of high-strength plastic (e.g. PTFE, PE-UHMW)
- and an integrated spring (e.g. high-grade/stainless steel, Hastelloy<sup>®(3)</sup> and Elgiloy<sup>®(3)</sup>)

After installation in the groove, the seal is pre-energized by the spring. The inherent pre-loading of the plastic groove seal (memory effect) and pre-loading of the spring assure the desired sealing performance even in case of low system pressures.

Since the seal is installed with the open side towards the higher system pressure, the sealing effect increases as system pressure rises. The steel spring has the additional purpose of compensating wear of the sealing lips to assure that a pre-defined contact pressure is maintained at constant levels throughout the seal's service life.

To cover the widest possible range of pressures and temperatures two basic seal types have been developed. These differ in terms of their housing geometries and, in particular, in terms of spring design and spring characteristics.

## **Benefits**

- Outstanding dry-running characteristics
- Low wear
- Low friction
- Variable friction conditions through choice of spring characteristics
- Extremely low breakaway forces even after prolonged down times
- No stick-slip even with low sliding speeds
- High dimensional stability
- High chemical and thermal resistance
- No volumetric change by swelling or shrinkage
- Compact seal, suitable for O-ring assembly spaces acc. to ARP 568 A, DIN 3771 and ISO 3601/1
- Good cost-benefit ratio
- Dimensions from Ø 2 to Ø 3000 mm available
- Very good wiping effect with abrasive media such as paints and lacquers

# Applications

## Application Examples

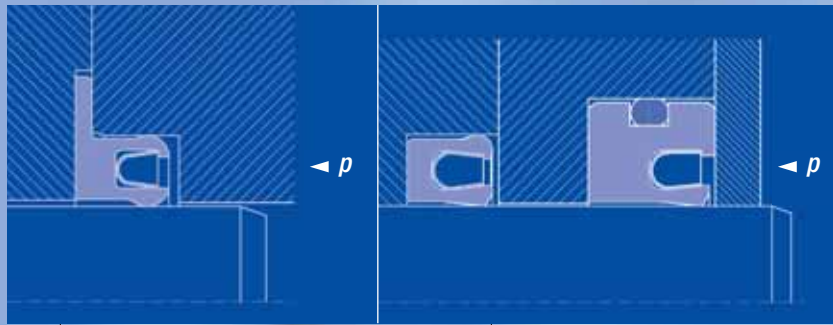

### Lab Technology

Piston pump in liquid chromatography equipment up to 300 bar for different chemical media and substances.

### Hydraulics

High-pressure axial piston pump for cleaning equipment up to 280 bar of water pressure and cleaning additives.

*Spring-energized seals are used in a wide range of industrial applications:*

- Automotive industry, e.g. direct fuel injection systems
- General manufacturing/mechanical engineering, e.g. CNC machines, compressors and vacuum pumps as well as tank systems
- Aerospace industry, e.g. in landing gear systems
- Food processing industry, e.g. in packaging machines and metering systems
- Medical and laboratory/analytical technology, e.g. in chromatography and endoscopy
- Painting technology, e.g. in paint valves
- Adhesives industry, e.g. as needle valve seals
- Hydraulics/pneumatics, e.g. in valves, solenoid valves, cylinders and pumps of all types
- Offshore technology, e.g. as petroleum and natural gas seals
- Chemical plant and equipment technology, e.g. in apparatus and container engineering

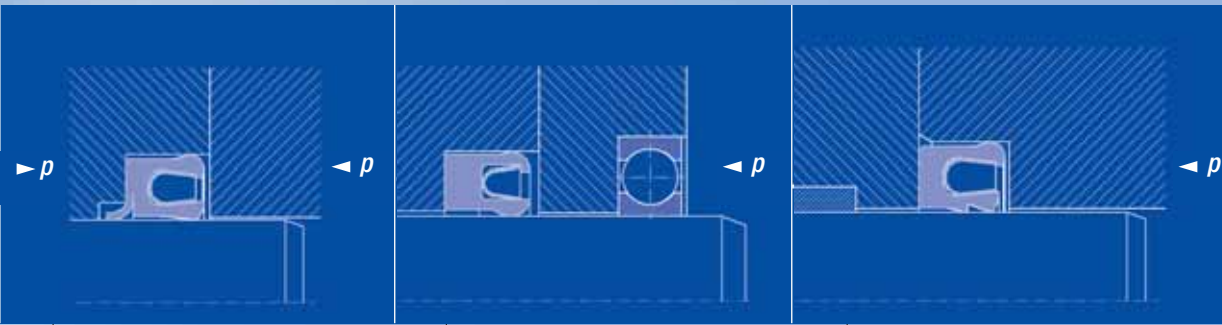

**Automotive Industry**  
Piston pump for media separation of gasoline/engine oil in gasoline direct injection system.

**Mechanical Engineering**  
CNC machine turret serving as rotary transmission for coolant/lubricant pressures up to 80 bar and as bearing seal.

**Painting Technology**  
Valve needle seal for paint pressures up to 20 bar; special seal geometry and special PE compounds ensure long service life and good wiping effect.

**Seal Design and Action Principle**

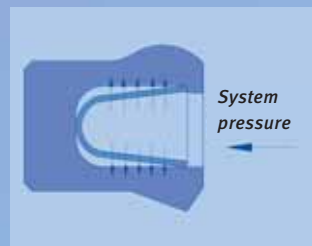
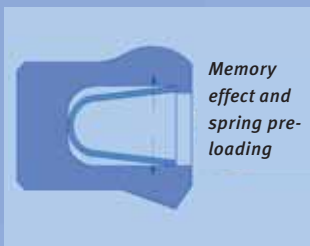
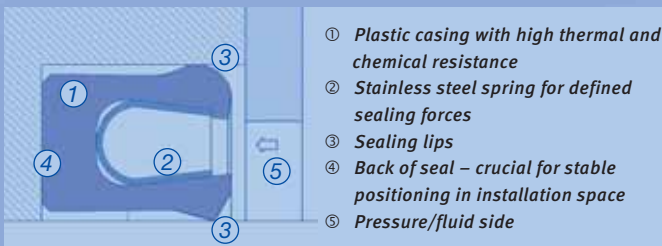

The action principle of all seal types and shapes is identical. The seals differ merely in terms of their profiles and the shape of the springs.

The sealing effect is achieved by the inherent pre-loading pressure of the plastic casing (memory effect of the compound) and the mechanical pre-loading force of the spring. The radial contact pressures are sufficient to effectively seal a pressureless application. In the event of additional system pressure, which may amount to some 100 bar, the contact pressure forces will rise along with the total sealing pressure.

# Standard Type URI



## URI – Rod Seal

For fluids.

With sharp-edged sealing lip on the external diameter for good wiping effect with rod seals.

### Operating Limits<sup>(1)</sup>

T = -75 °C to +300 °C

p = up to 250 bar

v = 15 m/s ⇄

## Preferential Range

Ordering example: URI – B12 – 332 – HS 21059 – C

URI = Seal type “Rod Seal“

B12 = Rod Ø 12

332 = Nominal cross-section

HS 21059 = Casing material (for other compounds see compound table pages 60 – 62)

C = Spring material (see page 29)

Rod Ø	Groove Base-Ø	Groove Width	Rod Ø	Groove Base-Ø	Groove Width
$B_{17}$	$A^{H9}$	$G^{+0.2}$	$B_{17}$	$A^{H9}$	$G^{+0.2}$
3	5.84	2.4	32	38.14	4.7
4	6.84	2.4	36	42.14	4.7
5	7.84	2.4	40	49.44	7.1
6	8.84	2.4	45	54.44	7.1
8	10.84	2.4	50	59.44	7.1
8	12.52	3.6	56	65.44	7.1
10	14.52	3.6	63	72.44	7.1
12	16.52	3.6	70	79.44	7.1
14	18.52	3.6	80	89.44	7.1
16	20.52	3.6	90	99.44	7.1
18	22.52	3.6	100	109.44	7.1
19	23.52	3.6	110	119.44	7.1
20	24.52	3.6	125	137.10	9.5
20	26.14	4.7	140	152.10	9.5
22	28.14	4.7	160	172.10	9.5
24	30.14	4.7	180	192.10	9.5
25	31.14	4.7	200	212.10	9.5
28	34.14	4.7			

## Installation Dimensions

Additional diameters/sizes from 2 mm to 3000 mm available on request.

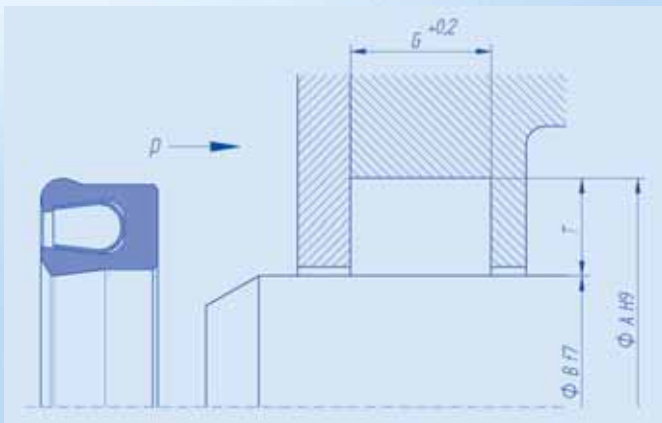

Rod Ø	Nominal Cross-Section <sup>(4)</sup>	Groove Base Ø	Groove Depth	Groove Width
$B_{17}$		$A^{H9}$	$T$	$G^{+0.2}$
2 – 10	116	Ø B + 2.84	1.42	2.4
10 – 20	332	Ø B + 4.52	2.26	3.6
20 – 40	108	Ø B + 6.14	3.07	4.7
40 – 120	316	Ø B + 9.44	4.72	7.1
120 – 1000	104	Ø B + 12.10	6.05	9.5
1000 – 3000	308	Ø B + 19.00	9.50	15.0

# Standard Type URA



## URA – Piston Seal

For fluids.

With sharp-edged sealing lip on the external diameter for good wiping effect with rod seals.

### Operating Limits<sup>(1)</sup>

T = -75 °C to +300 °C

p = up to 250 bar

v = 15 m/s ⇄

## Preferential Range

Ordering example: URA – A50 – 316 – HS 21037 – C

URA = Type, “Piston Seal”

A50 = Cylinder Ø 50

316 = Nominal cross-section

HS 21037 = Casing material (for other compounds see compound table pages 60 – 62)

C = Spring material (see page 29)

Cylinder Ø	Groove Base Ø	Groove Width	Cylinder Ø	Groove Base Ø	Groove Width
$B_{17}$	$A^{H9}$	$G^{+0.2}$	$B_{17}$	$A^{H9}$	$G^{+0.2}$
8	5.16	2.4	36	29.86	4.7
10	7.16	2.4	40	33.86	4.7
12	9.16	2.4	50	40.56	7.1
14	9.48	3.6	60	50.56	7.1
16	11.48	3.6	63	53.56	7.1
18	13.48	3.6	70	60.56	7.1
20	15.48	3.6	80	70.56	7.1
22	17.48	3.6	100	90.56	7.1
24	19.48	3.6	125	112.90	9.5
25	20.48	3.6	140	127.90	9.5
25	18.86	4.7	160	147.90	9.5
28	21.86	4.7	180	167.90	9.5
30	23.86	4.7	200	187.90	9.5
32	25.86	4.7			

Additional diameters/sizes from 2 mm to 3000 mm available on request.

## Installation Dimensions

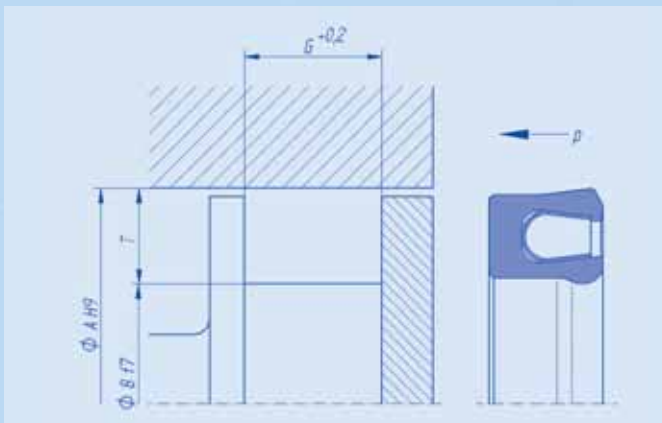

Cylinder Ø	Nominal Cross-Section <sup>(4)</sup>	Groove Base Ø	Groove Depth	Groove Width
$A^{H9}$		$B_{17}$	T	$G^{+0.2}$
6 – 14	116	Ø A – 2.84	1.42	2.4
14 – 25	332	Ø A – 4.52	2.26	3.6
25 – 45	108	Ø A – 6.14	3.07	4.7
45 – 125	316	Ø A – 9.44	4.72	7.1
125 – 1000	104	Ø A – 12.10	6.05	9.5
1000 – 3000	308	Ø A – 19.00	9.50	15.0

# Standard Type URF



## URF – Shaft and Rod Seal

With clamping flange for sealing rotary and swiveling applications.

### Operating Limits<sup>(1)</sup>

T = -75 °C to +300 °C

p = up to 200 bar

v = 15 m/s ⇄

v = 2.5 m/s ↻

### Preferential Range

Ordering example: URF – B20 – 108 – HS 21037 – C

URF = Seal type “Shaft Seal”

B20 = Shaft Ø 20

108 = Nominal cross-section

HS 21037 = Casing material (for other compounds see compound table  pages 60 – 62)

C = Spring material (see page 29)

Shaft Diameter Ø B <sub>17</sub>	Groove Base Ø A <sup>H9</sup>	Groove Width G1 min	Shaft Diameter Ø B <sub>17</sub>	Groove Base Ø A <sup>H9</sup>	Groove Width G1 min
3	5.84	2.4	42	51.44	7.1
5	9.52	3.6	45	54.44	7.1
6	10.52	3.6	50	59.44	7.1
8	12.52	3.6	56	65.44	7.1
10	14.52	3.6	60	69.44	7.1
12	16.52	3.6	63	72.44	7.1
14	18.52	3.6	70	79.44	7.1
16	20.52	3.6	80	89.44	7.1
18	22.52	3.6	90	99.44	7.1
20	26.14	4.7	100	109.44	7.1
22	28.14	4.7	110	119.44	7.1
24	30.14	4.7	120	129.44	7.1
25	31.14	4.7	125	137.10	9.5
28	34.14	4.7	130	142.10	9.5
30	36.14	4.7	140	152.10	9.5
32	38.14	4.7	160	172.10	9.5
35	41.14	4.7	180	192.10	9.5
36	42.14	4.7	200	212.10	9.5
40	49.44	7.1			

### Installation Dimensions

Additional diameters/sizes from 2 mm to 3000 mm available on request.

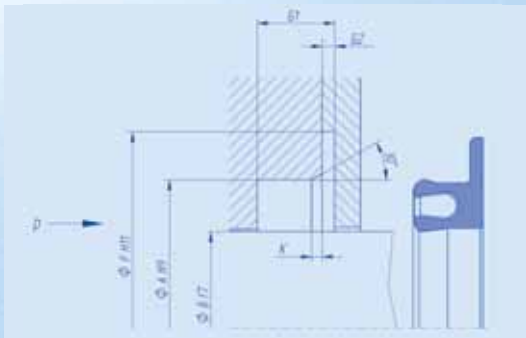

Shaft Ø B <sub>17</sub>	Nominal Cross-Section <sup>(4)</sup>	Groove Base A <sup>H9</sup>	Flange Ø F <sup>H11</sup>	Groove Width G1 min	Groove Width G2 <sub>-0.1</sub>	Lead-In Chamfer K
3 – 5	116	Ø B + 2.84	Ø B + 6.5	2.4	0.70	0.6
5 – 20	332	Ø B + 4.52	Ø B + 8.5	3.6	0.85	0.8
20 – 40	108	Ø B + 6.14	Ø B + 12.0	4.7	1.35	1.1
40 – 120	316	Ø B + 9.44	Ø B + 16.5	7.1	1.80	1.4
120 – 1000	104	Ø B + 12.10	Ø B + 21.0	9.5	2.80	1.7
1000 – 3000	308	Ø B + 19.00	Ø B + 27.5	15.0	3.80	2.0

## Standard Types URS | CRS



### URS – Piston and Rod Seal | Shaft Seal

For gaseous media.

Chamfered sealing lip with large wear reserve; even with rotary and swiveling applications.

#### **Operating Limits<sup>(1)</sup>**

$T = -75\text{ °C to }+300\text{ °C}$

$p = \text{up to } 250\text{ bar}$

$v = 15\text{ m/s} \leftrightarrow$

$v = 1\text{ m/s} \curvearrowright$



### CRS – Piston and Rod Seal | Static Seal

Very good sealing performance with high pressures. Static sealing action and/or for slow-moving applications.

#### **Operating Limits<sup>(1)</sup>**

$T = -95\text{ °C to }+300\text{ °C}$

$p = \text{up to } 700\text{ bar}$

$v = 0.5\text{ m/s} \leftrightarrow$



## Special Versions URV | CRV | Piston and Rod Seal



### URV Rod Seal | Shaft Seal

For fluids.

With shortened, sharp-lipped interior sealing lip for good wiping effect; also suitable for sealing rotary and swiveling applications.



### CRV Rod Seal

For fluids.

With sharp-edged interior sealing lip for good sealing effect with high pressures; very good wiping effect.



### Piston and Rod Seal

For critical fluids  
(paint, lacquers, gasoline, etc.).

Double sealing edge for improved sealing performance.



### Rod Seal

For separating two media.

Groove seal with integrated memory sealing lip.



### Piston and Rod Seal

For extra-large installation dimensions.



### Rod Seal | Shaft Seal

With O-ring as static seal.

Very good static sealing effect at the external diameter and/or with rough housing surfaces.



### Piston and Rod Seal

For high pressure loads with special design and reinforced back of seal.

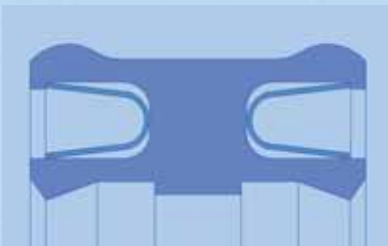

### Rod Seal

(Could also be designed as a piston seal.)

For separating two media.



### Complete Piston/Complete Package Solution

Design available on request.

#### **Benefits:**

- One-part piston
- Replaces metal piston by plastic piston
- Ready-/easy-to assemble versions with favorable cost-benefit ratio
- No damage to seals during assembly process
- Complete package solution, incl. seal and integrated guidance, available

# Type Static Flange Seals

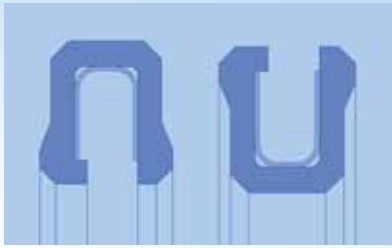

## Standard Version

**UAI for internal pressure (left).**  
**UAA for external pressure (right).**  
 Rotary seal for rotating and swiveling motions.

### Operating Limits<sup>(1)</sup>

T = -75 °C to +300 °C  
 p = up to 250 bar  
 v = 2.5 m/s

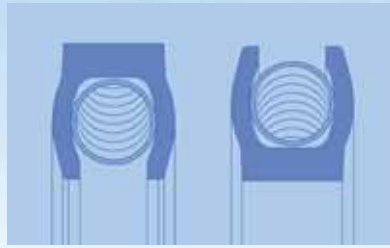

## Standard Version

**CAI for internal pressure (left).**  
**CAA for external pressure (right).**  
 Rotary seal for rotating and swiveling motions.

### Operating Limits<sup>(1)</sup>

T = -95 °C to +300 °C  
 p = up to 700 bar  
 v = 0.5 m/s

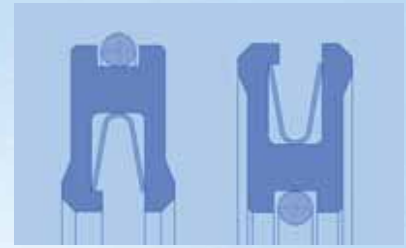

## Special Version

**Internal pressure (left).**  
**External pressure (right).**  
 Rotary seal for rotating and swiveling motions.

## Installation Dimensions for internal pressure

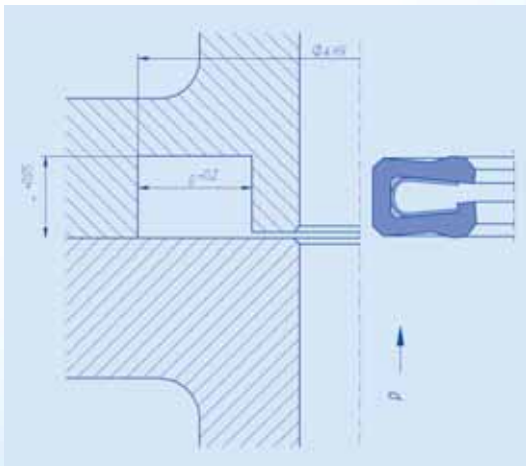

Groove Ext Ø A <sup>H9</sup>	Nominal Cross- Section <sup>(4)</sup>	Groove Depth T <sup>+0.05</sup>	Groove Width G <sup>+0.2</sup>
10 – 70	116	1.42	2.4
12 – 180	332	2.26	3.6
24 – 480	108	3.07	4.7
46 – 700	316	4.72	7.1
125 – 1000	104	6.05	9.5
1000 – 3000	308	9.50	15.0

## for external pressure

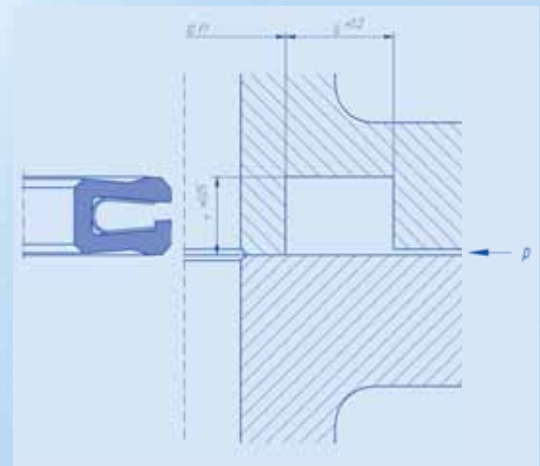

Groove Int Ø ID <sub>T</sub>	Nominal Cross- Section <sup>(4)</sup>	Groove Depth T <sup>+0.05</sup>	Groove Width G <sup>+0.2</sup>
3 – 60	116	1.42	2.4
8 – 160	332	2.26	3.6
20 – 380	108	3.07	4.7
40 – 460	316	4.72	7.1
100 – 1000	104	6.05	9.5
1000 – 3000	308	9.50	15.0

# Technical Details



## Spring Types | Spring Characteristics | Spring Materials

To assure that the sealing lips are permanently pressed against the contact surfaces, spring-energized seals made from PTFE and PE compounds require metal spring elements that are integrated in the plastic casings. In special cases, these may be elastomer O-rings as well. Most seals, however, have metal springs.

The spring assures constantly even contact pressure of the sealing lip across the entire temperature range.

For the different types of seals different types of springs are available with particular spring characteristics. These spring characteristics and properties have a major influence on sealing performance, friction and wear behavior of the groove seal.

### Spring Types

#### U- and/or V-Spring



These standardized spring types are used in all U-shaped versions, such as the standard URI, URA, URS rod and piston seals and the URF shaft seals.

Both types are primarily used in dynamic sealing applications, as relatively low spring forces are achieved with large spring travel. In high-speed applications this results in low wear of the dynamic sealing lips. With their maximum pre-loading force, the spring ends directly act on the sealing edges of the sealing lips, thus generating optimum compression development. The highly flexible springs are capable of providing better compensation for larger groove tolerances, coaxiality flaws and misalignments.

#### C-Spring



The C-spring is a spiral type wound from metallic tape and excels at offering high spring forces even at low rates of spring travel. These springs are recommended primarily for use in static and/or slow-moving and high-pressure sealing applications.

The high pre-loading forces ensure excellent sealing performance both with fluid and gaseous media. This spring type is particularly well suited for low-temperature applications.

#### Special Springs

Additional special spring types available on request.

# Technical Details

## Spring Characteristics

This map shows the various spring characteristics related to the individual nominal cross-sections, clearly revealing the differences between U-, V- and/or C-springs. This data based on a 20 mm length of spring.

Purpose-manufactured special springs for friction-optimized seals assure minimum contact pressures with large rates of spring travel. This enables us to make pinpoint calculations and proposals for seals offering high wear reserves and thus prolonged service life.

### U-Spring compared to C-Spring<sup>(2)</sup>

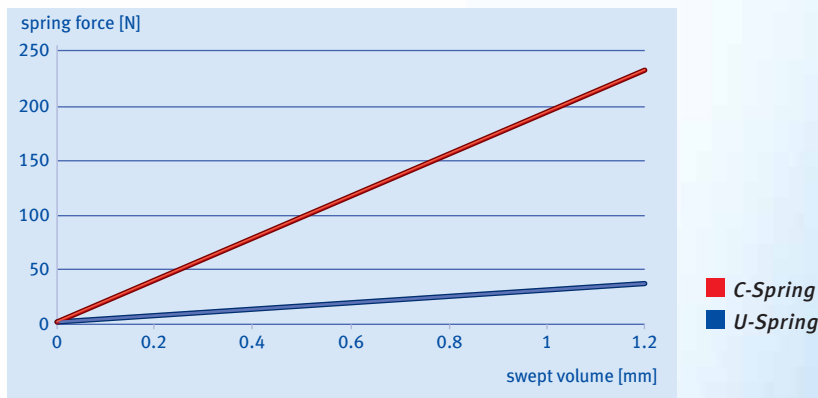

### Spring Characteristics U-Spring<sup>(2)</sup>

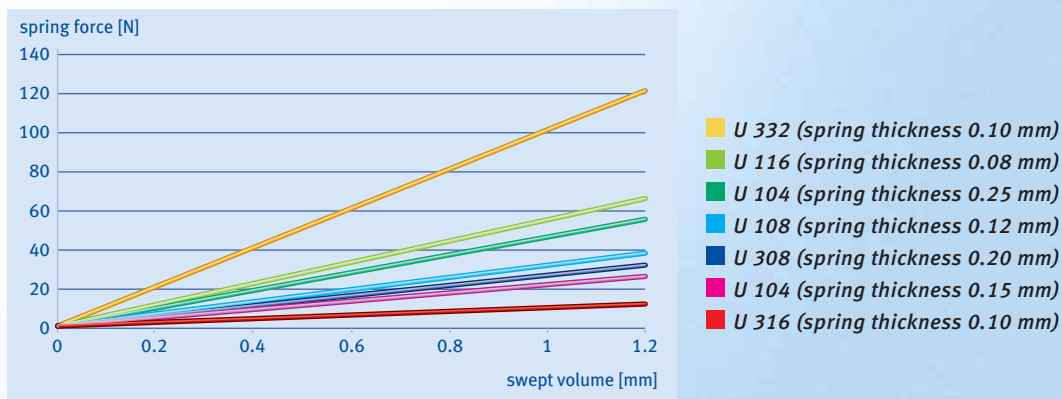

### Spring Characteristics C-Spring<sup>(2)</sup>

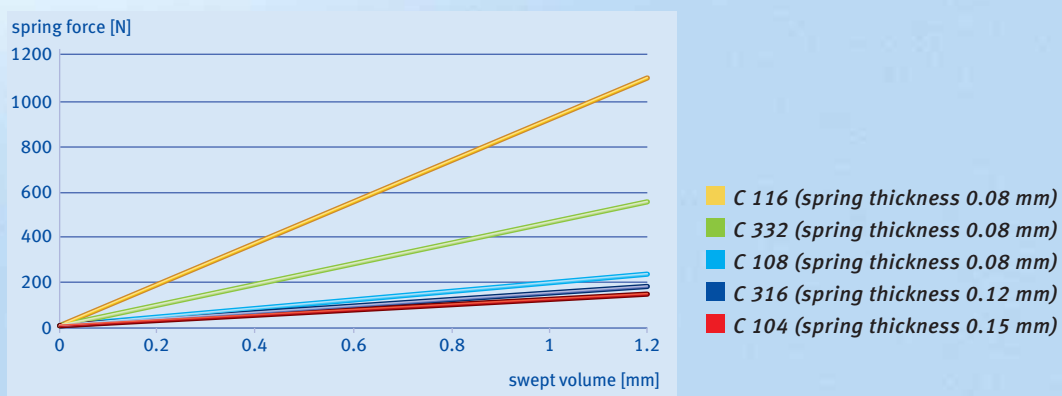



### Spring Materials

Standard spring material C: Stainless steel  
Material: 1.4310  
X12Cr Ni 177  
A ISI 301

### Special materials:

Hastelloy<sup>®(3)</sup> C 276 H: Hastelloy<sup>®</sup> C-276  
Material: 2.4819  
Ni Mo 16Cr 15W  
UNS N 10276

Elgiloy<sup>®(3)</sup> E: Elgiloy<sup>®</sup>  
Material: 2.4711  
Co Cr 20 Ni 15 Mo  
UNSR 30003

Other special spring materials available on request.

### Operating Limits<sup>(1)</sup>

#### Dynamic Seals<sup>(2)</sup>

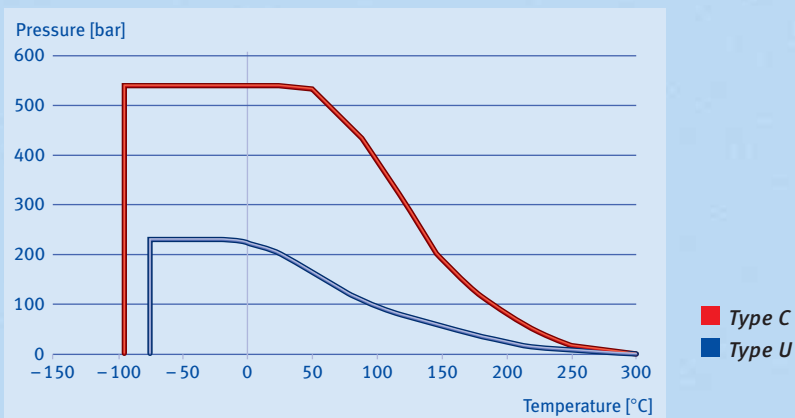

#### Static Seals<sup>(2)</sup>

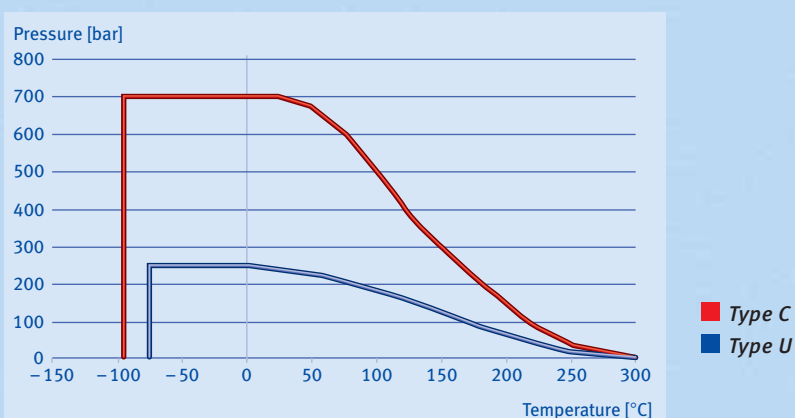

## Technical Details

### **Displacement Force<sup>(2)</sup>**

The diagram shows the different displacement forces of spring-energized seals with a U/V-spring, C-spring compared to the conventional hydraulic seal, which is an O-ring-pre-loaded PTFE stepped seal (SRI). The differences in displacement forces are the result of different levels of radial contact pressures of the seal against the rod.

The CRS type with the wound spiral spring tape produces significantly higher contact pressure and thus displacement force than the URI type.

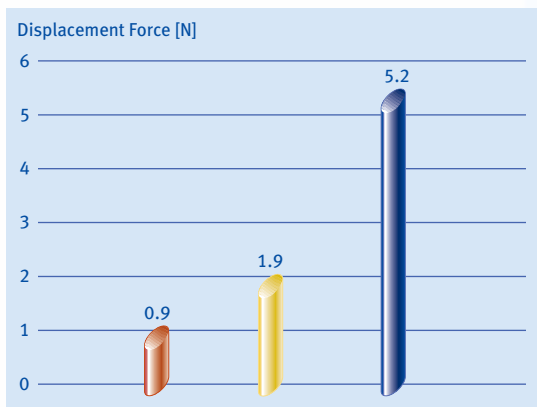

- Spring-energized seal, type URI
- Stepped seal, SRI with O-ring
- Spring-energized seal, type CRS

### **Test Conditions:**

Hydraulic cylinder rod  $\varnothing$  11 mm, hard-chrome-plated, Rz 0.2  $\mu$ m, v = 60 mm/min, pressureless, oil-lubricated, room temperature.

## Design and Fitting Instructions

- Assure good surface finish of fitting tapers/lead-in chamfers on cylinder barrel and piston rod
- Deburr and round off all sharp edges
- In special cases, heating of the sealing ring is recommended
- Cover crest of threads
- Carefully remove dust, dirt, chips, swarf, etc.
- Do not use any sharp-edged fitting tools
- We recommend snap-in assembly into the semi-closed groove as shown in sketch on page 31 using a conical fitting tool and an expanding sleeve. These instructions should be observed particularly with small seal diameters
- Do not deform seals
- Greasing/oiling of sliding surfaces and seals during assembly facilitates fitting and is recommended. Do not use any greases with solid additives
- Installation into closed grooves is only possible in some cases and requires special prerequisites to be met, such as minimum diameter, axial distance of the groove, heating of the seal ring. Please contact us for assistance

# Design and Fitting Instructions

## Rod Seal

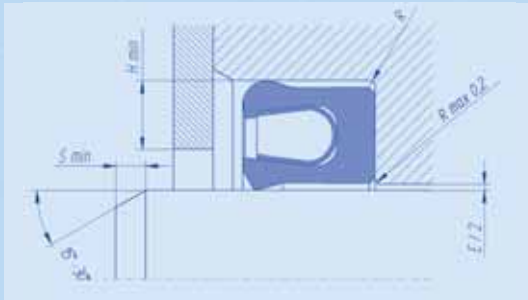

Installation into split groove

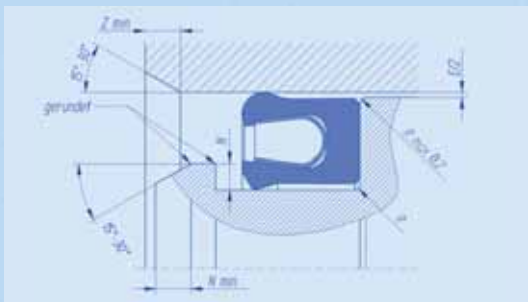

Installation into semi-closed groove  
(Snap-in assembly)

## Snap-in assembly

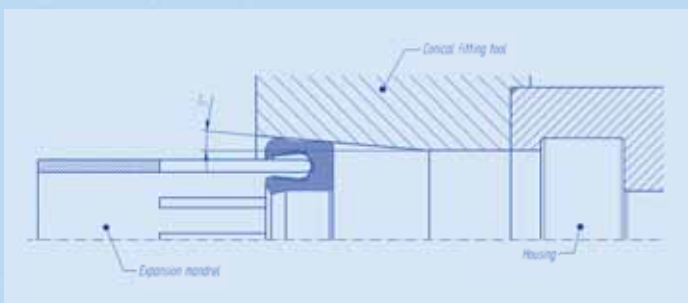

Nominal Cross-Sec- tion <sup>(4)</sup>	Lead-in Chamfer Rod		Retainer H or H <sub>min</sub>	Fitting Taper- Housing		Radius Radial- Clearance	
	15° Phase	30° Phase		N <sub>min</sub> at 15° Phase	N <sub>min</sub> at 30° Phase	R	ce <sub>max</sub> E/2
116	2.6	1.2	0.4	1.5	0.7	0.20	0.05
332	4.1	1.9	0.5	2.3	1.0	0.20	0.07
108	5.2	2.4	0.6	3.0	1.4	0.25	0.08
316	7.5	3.5	0.8	4.5	2.1	0.30	0.10
104	10.4	4.8	1.0	5.6	2.6	0.35	0.12
308	12.0	6.0	1.2	7.0	3.2	0.35	0.15

## Piston Seal

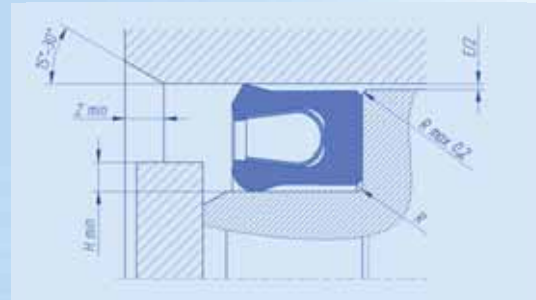

Installation into split groove

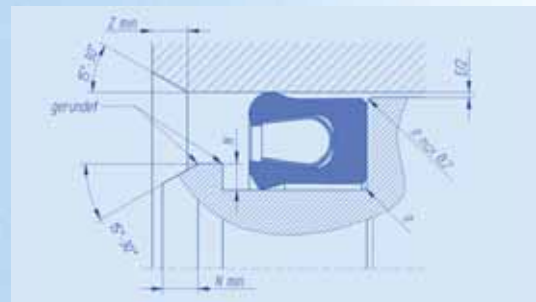

Installation into semi-closed groove  
(Snap-in assembly)

## Snap-in assembly

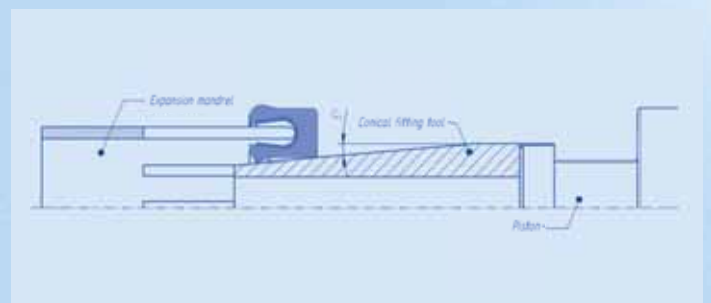

Nominal Cross-Sec- tion <sup>(4)</sup>	Lead-in Chamfer Cylinder		Retainer H or H <sub>min</sub>	Fitting Taper- Piston		Radius Radial- Clearance	
	15° Phase	30° Phase		N <sub>min</sub> at 15° Phase	N <sub>min</sub> at 30° Phase	R	ce <sub>max</sub> E/2
116	2.6	1.2	0.4	1.5	0.7	0.20	0.05
332	4.1	1.9	0.5	2.3	1.0	0.20	0.07
108	5.2	2.4	0.6	3.0	1.4	0.25	0.08
316	7.5	3.5	0.8	4.5	2.1	0.30	0.10
104	10.4	4.8	1.0	5.6	2.6	0.35	0.12
308	12.0	6.0	1.2	7.0	3.2	0.35	0.15



# Surface Quality

The crucial factor affecting the sealing function, sealing performance and service life of the seal is the surface quality of the contact surface.

Grooving, scoring, scratching and traces of machining must be avoided. In a sealing system, any of these will lead to leakage as well as damage to the sealing lips.

The following surface roughness values of the dynamic and static sealing surface are recommended:

## Dynamic sealing surface

	<i>Piston and rod seals e.g. URI, URA, URS</i>	<i>Shaft seals e.g. URF</i>
Ra	≤ 0.1 µm	≤ 0.2 µm
Rz	≤ 1.0 µm	≤ 1.6 µm
Rmax	≤ 2.0 µm	≤ 2.0 µm

## Static sealing surface

	<i>Piston and rod seals e.g. URI, URA, URS</i>	<i>Shaft seals e.g. URF</i>
Ra	≤ 0.4 µm	≤ 0.4 µm
Rz	≤ 2.5 µm	≤ 2.5 µm
Rmax	≤ 6.3 µm	≤ 6.3 µm

Surface hardness of shaft seals ≥ 58 HRC non-twisting.

Particularly with piston and rod seals, e.g. types URI, URA and URS, the material content/bearing content of the surface is crucial. As such, even roller-burnished or ground/polished stainless steel rods or needles achieve a high material content of ≥ 75% measured at a cut depth of  $c = 25\%$  of the Rz-value based on a reference value of 5%.

*The following surface structures illustrate this point:*

Ideal contact surface for piston and rod seals, e.g. achieved by roller-burnishing, honing, grinding/polishing.



*Material content 75% at  
Rz-value 1.0 µm  
→ good sealing effect  
→ long service life*

Cracked contact surface, not optimally suited.



*Material content 20% at same  
Rz-value of 1.0 µm  
→ lower sealing effect  
→ wear of sealing lip*

For shaft seals, e.g. type URF, we recommend hardened steel shafts ground without twists. Many applications also use coatings such as chromium oxide, tungsten carbide, carbon coatings, etc. When such coatings are used, a very good surface quality (Rz ≤ 1.0 µm) must be assured. Otherwise, these extremely hard coatings cause excessive wear of the sealing lip. We also recommend you consider having our development department perform respective wear tests in such cases.



### **Compounds**

As a specialist in the field of PTFE we offer a wide range of different PTFE compounds for virtually any application requirement. A selection of the major compounds has been compiled in the compound chapter on pages 61 – 63.

### **Storage Instructions**

As a general rule, seals must be stored in such a way that any damage resulting from external shock or pressure is precluded. Sealing lips must be protected from deformation under all circumstances. Spring-energized seals made from PTFE compounds have a virtually unlimited shelf life.

PTFE-based seals should be placed and picked using the First-in-First-out principle. Maximum storage period is app. 1 year, provided the seals are stored in dry conditions and protected from exposure to UV light.

