

PTFE and Moldflon™ Friction Bearings

New Freedom for High Demands in Bearing Technology

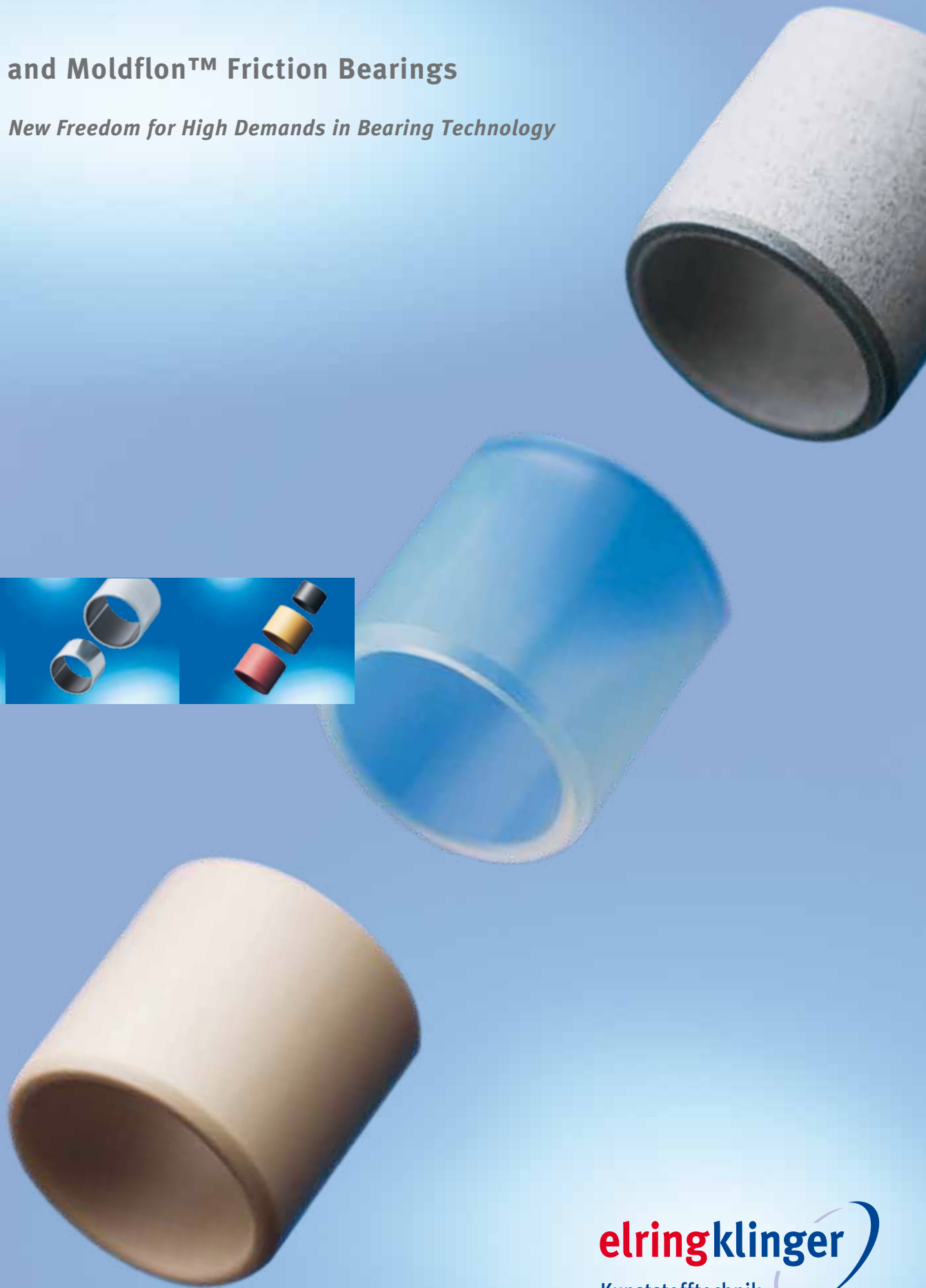

PTFE and Moldflon™ Friction Bearings: Product Range

Pages 4–7

Pages 8–11

Pages 12–15

Pages 16–19

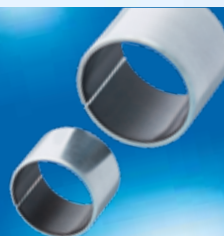
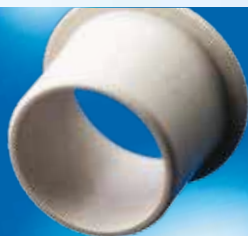
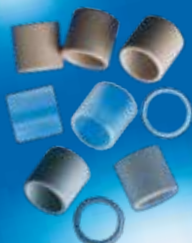

**Overview
Selection**

**Friction Bearings made of
Moldflon™ for High p-v Values**

**M-Liner Dry Friction Bearing
for Good Heat Dissipation**

**Friction Bearings made of
Elringplast for High Wear
Resistance**



Innovations in plastic

With PTFE seals and design elements, ElringKlinger Kunststofftechnik has been a technology leader for over 50 years. We develop and produce individual, practical solutions made of PTFE and PTFE compounds, and other high-performance plastics, for our customers around the world. Our solutions fulfill the toughest requirements in the real world—economically and reliably.

Maximum performance and functional reliability

Friction bearings made of Moldflon™ and highly wear-resistant PTFE compounds: the right choice for high p-v values and high thermal loads, even in case of insufficient lubrication or dry applications. Our friction bearings feature both excellent tribological properties and chemical resistance to aggressive media.

They are the first choice for applications in the food and medical product industries.

Technical consultation

We will be happy to support you in selecting the optimal friction bearing, providing you with the most functional and economical custom-tailored solution for your application.

Simply fill out the technical questionnaire (page 23) and send it to us, or contact us directly.

Pages 20–21



Application Examples



Pages 22–23



**Design Information
Technical Questionnaire**



Quality and environmental policy

Top quality and active environmental protection are prerequisites for the sustained success of our company. We are certified to ISO/TS 16949 and DIN EN ISO 14001.

(1) Design limits:

The information provided here has been collected with great care on the basis of many years of experience. However, no guarantee can be provided for the data, because proper function can be ensured only if the particular conditions of each individual case are taken into consideration. We recommend that prototypes be used and tests performed for each case. Our development department, with its versatile capabilities for characterizing materials, determining technical application properties, or performing component and system tests on appropriate test benches, is also available to assist.

(2) Diagrams:

The data in the diagrams are based on comparison values determined by ElringKlinger. They were derived under special, defined conditions, and cannot be applied exactly to other applications. The diagrams allow basic comparisons of our friction bearings and materials.

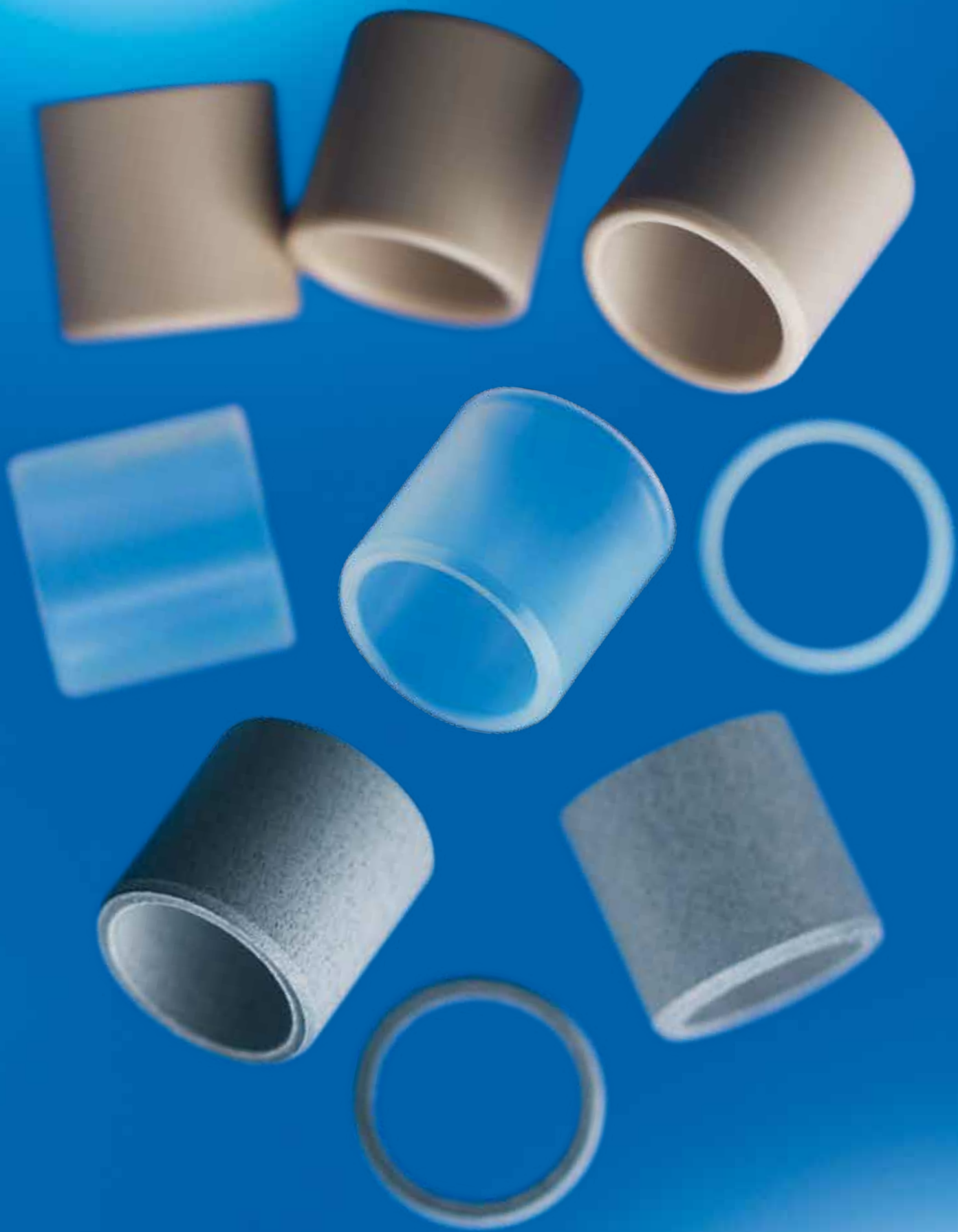

Overview and Selection



For many years, PTFE friction bearings made of Elringplast J, LD, and W2 have been a solid component in machine design for demanding requirements. The development of the new dry friction bearing made of Moldflon™ (thermoplastic process-able PTFE) has made it possible to further improve characteristics that are critical to friction bearings, such as compressive strength and wear resistance.

Advantages

- Excellent chemical resistance
- Large temperature range of -100°C to +250°C
- Suitable for high circumferential speeds under dry running conditions
- Suitable for high p-v values under dry running conditions
- FDA-compliant materials for Life Science applications

Selection by Main Criteria

<i>Properties</i>	<i>Materials</i>	<i>Moldflon™ friction bearings</i>			<i>M-Liner</i>	<i>Elringplast friction bearings</i>		
		<i>MF 10005</i>	<i>MF 40002</i>	<i>MF 40003</i>	<i>M-Liner</i>	<i>Elring- plast W2</i>	<i>Elring- plast J</i>	<i>Elring- plast LD</i>
Under high loads			•	◦				
At high speeds		•	•	•	•	•	•	•
Low friction		•	◦	◦	◦		◦	
Low wear			•	•	•		•	•
At high temperatures		•	•	•	•	•	•	•
Good heat dissipation					•	◦		
For aggressive media		•	•	•		◦	◦	◦
For food applications		•	•					
For soft shafts		•					◦	
Vibration-damping		•	◦				◦	
For edge pressure		•	◦				◦	
For dampness		•	•	•		•		•
Low-cost					•			•

• *Very well suited* ◦ *Suited*

Selection by Characteristic Values



Wear

Wear of friction bearings depends on a number of influence factors, such as the load, speed, temperature, and contact pairing. Therefore, it is all the more important that the optimal bearing for the application is selected.

The wear rate of food-compatible friction bearings made of Moldflon™ is several factors lower than that of typical commercial all-plastic friction bearings.

Test parameters:

rotating, shaft X90, $p = 0.75 \text{ N/mm}^2$, $v = 0.83 \text{ m/s}$

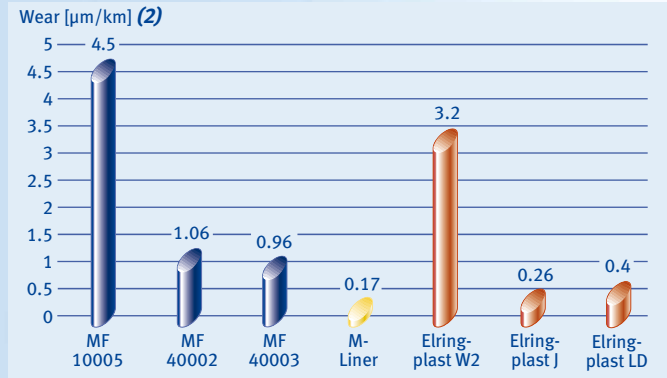

Surface pressure

The bearing load is represented by the surface pressure (p) in N/mm^2 (corresponds to MPa).

The radial load is distributed over the project surface area:

$$p = \frac{F}{B \cdot d}$$

F... load in N
B... bearing length in mm
d... inner bearing diameter in mm

The characteristic value indicates the limit of the load capacity of the bearing.

Test parameters:

static, room temperature

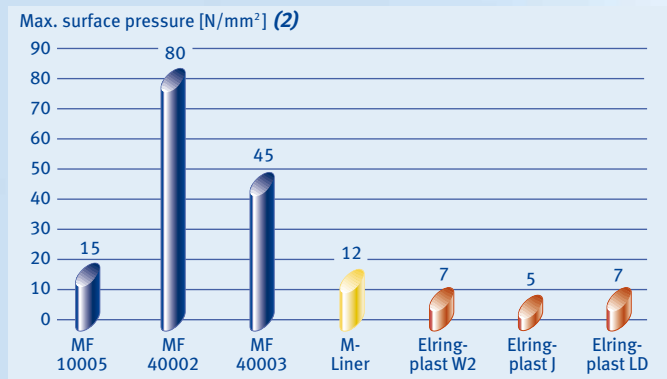

p·v value

One of the most meaningful characteristics for designing a friction bearing is the product of the specific load (p) and the bearing speed (v). The p·v value indicates the basic suitability of a bearing for a specific application.

Friction bearings from ElringKlinger Kunststofftechnik GmbH combine various properties in one component. They thereby provide solutions to difficult tribological applications—a new dimension in friction bearing technology.

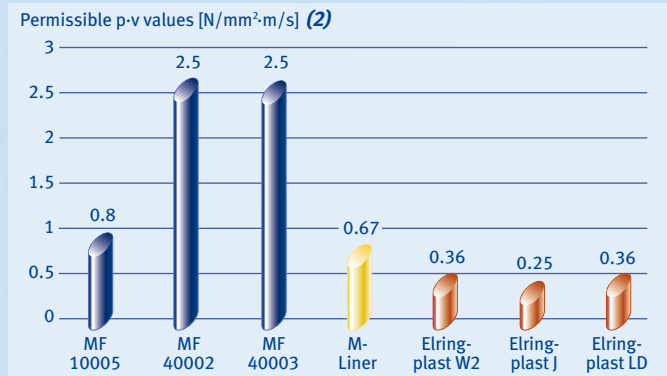



Moldflon™ Friction Bearings



Moldflon™ is a PTFE material that, in contrast to the typical press and sinter method, can be used in thermoplastic processes such as injection molding.

Its properties, such as chemical resistance, low creep tendency, and very good tribological properties, mean that Moldflon™ is predestined to be a bearing material. It can be used for:

- Friction bearings
- Slide rails
- Thrust washers

The cold flow of the unfilled Moldflon™ is less than that of all typical PTFE compounds, and is comparable to the value of highly filled compounds. This is achieved without the disadvantages of PTFE compounds caused by fillers, such as limited chemical resistance or restricted scope of approval for food applications.

Advantages

- Very low friction coefficient
- High circumferential speeds
- Excellent wear characteristics
- Very high p-v values under dry running conditions
- Very high static compressive strength
- No moisture absorption
- Corrosion-free

With respect to additional properties that are typical for PTFE, such as good sliding characteristics, resistance to UV light, or aging resistance, Moldflon™ is equal to PTFE in every way.

Standard friction bearings are manufactured according to ISO 3547 and DIN 1850.

The injection molding process used for manufacture places nearly no limitations on design. Special dimensions and customer-specific designs can thus be realized without a problem.

Product characteristics (1)

	Moldflon™ Compound MF 10005	Moldflon™ Compound MF 40002	Moldflon™ Compound MF 40003
Color	White	Brown	Black
FDA conformity	yes	yes	no
Max. p-v value [N/mm ² · m/s]	0.8	2.5	2.5
Max. speed [m/s] (dry)	5	1.5	1.5
Max. stat. surface pressure [N/mm ²]	15	80	45
Max. application temperature [°C]	-100 to +250	-100 to +250	-100 to +250
Friction coefficient μ (dry running conditions, shaft X90, p = 0.75 N/mm ² , v = 0.83 m/s)	0.19	0.29	0.3
Thermal expansion coefficient (1/K · 10 ⁻⁵)	12.40	7.3	
Density (g/cm ³)	2.14	1.4	1.91
Water absorption [%]	< 0.01	< 0.01	< 0.01

Dimensions per DIN ISO 3547-1 and special dimensions. Please request your desired dimensions.

Cold flow (2)

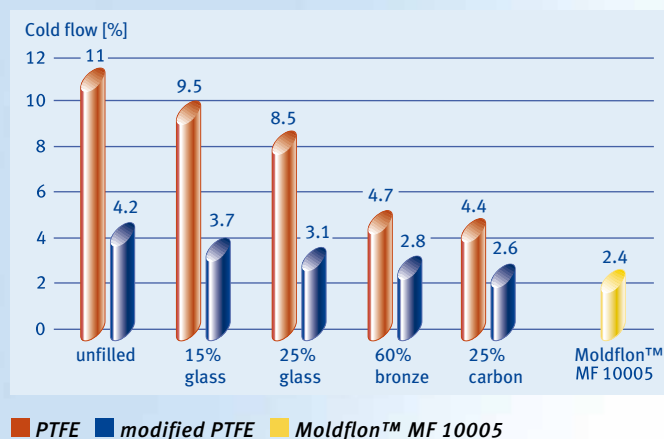

Technical Details

p-v values

The limits of application of the Moldflon™ friction bearings can be derived from the following characteristic curves. Depending on the sliding speed and the specific load, each plotted characteristic curve indicates the maximum load under suitable conditions.

Moldflon™ MF 10005

- Material especially for applications in the food industry and medical technology, conforms to FDA and USP Class VI
- For circumferential speeds of up to 5 m/s
- Suitable for soft shafts
- With very good damping characteristics
- With very good friction coefficients

Permissible p-v values (2)

Test parameters: friction bearing with 1 mm wall thickness, steel shaft

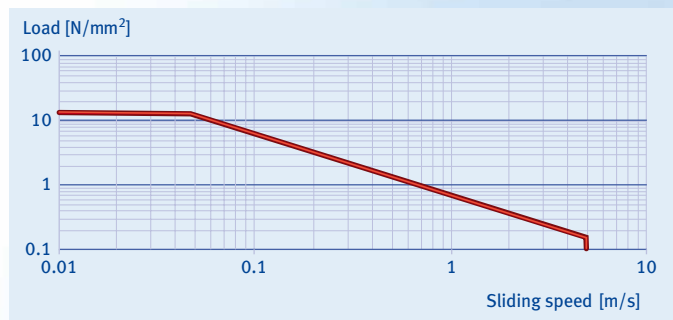

Moldflon™ MF 40002

- Material for applications in the food industry, conforms to FDA
- For p-v values of up to 2.5 N/mm²·m/s
- For high surface pressures of up to 80 N/mm²
- With high wear resistance

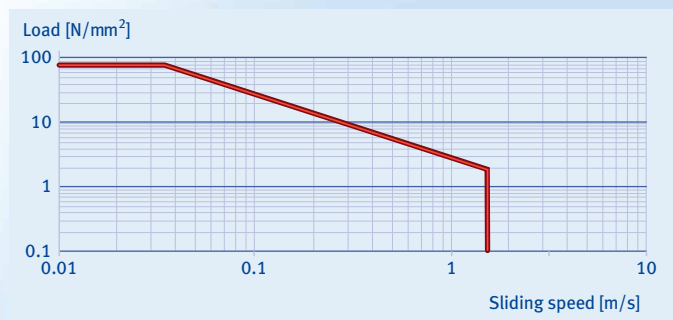

Moldflon™ MF 40003

- The friction bearing for p-v values of up to 2.5 N/mm²·m/s
- With high wear resistance

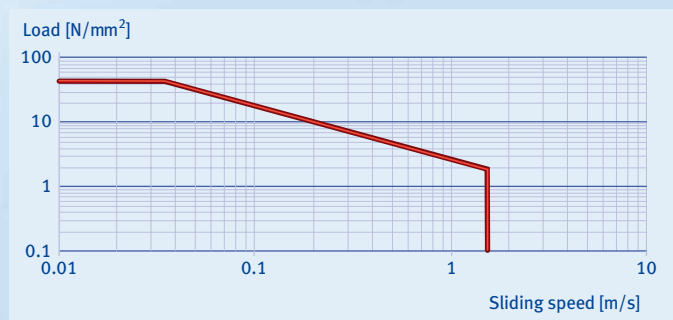

Wear with different contact surfaces

The material, hardness, and roughness of the contact surface all have a decisive influence on the wear behavior, and thus the service life, of the friction bearing.

Notes for designing the contact surface are described in the Design Information chapter on page 22.

Test parameters: $t = 100$ h, rotating, $p \cdot v = 0.623$, $D = 8$ mm

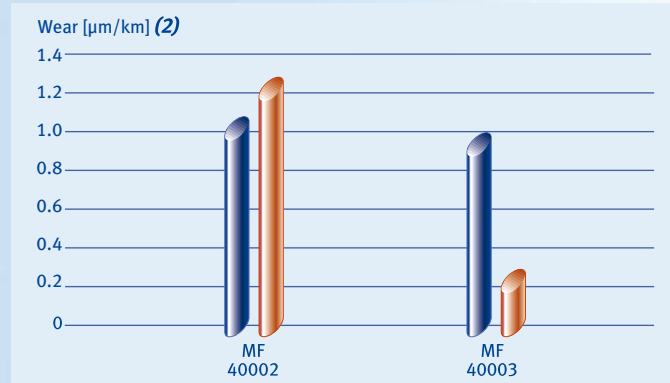

- X90CrMoV18, hardened and ground
- Hard-anodized aluminum

Maximum recommended load as a function of temperature

Moldflon™ friction bearings can generally be used in a temperature range from -100°C to $+250^{\circ}\text{C}$. The compressive strength decreases with increasing temperature.

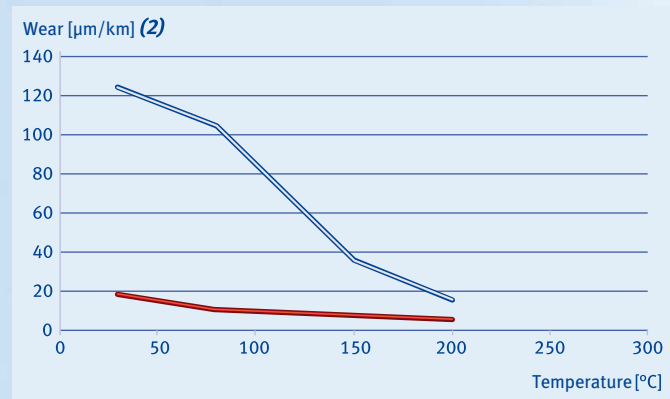

- MF 10005
- MF 40002

Friction coefficient as a function of the sliding speed

The friction coefficient μ indicates the force that must be exerted in order to slide one body against another. A distinction is made between static and dynamic friction coefficients.

The friction coefficient varies, depending on the sliding pair and application parameters. The lower the friction coefficient, the less heat development by the friction bearing. This has a positive effect on wear behavior.

Test parameters: steel shaft, $p = 0.625$ N/mm²

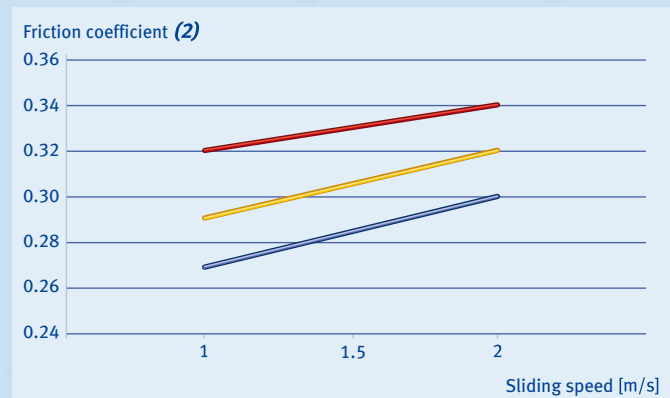

- MF 10005
- MF 40002
- MF 40003

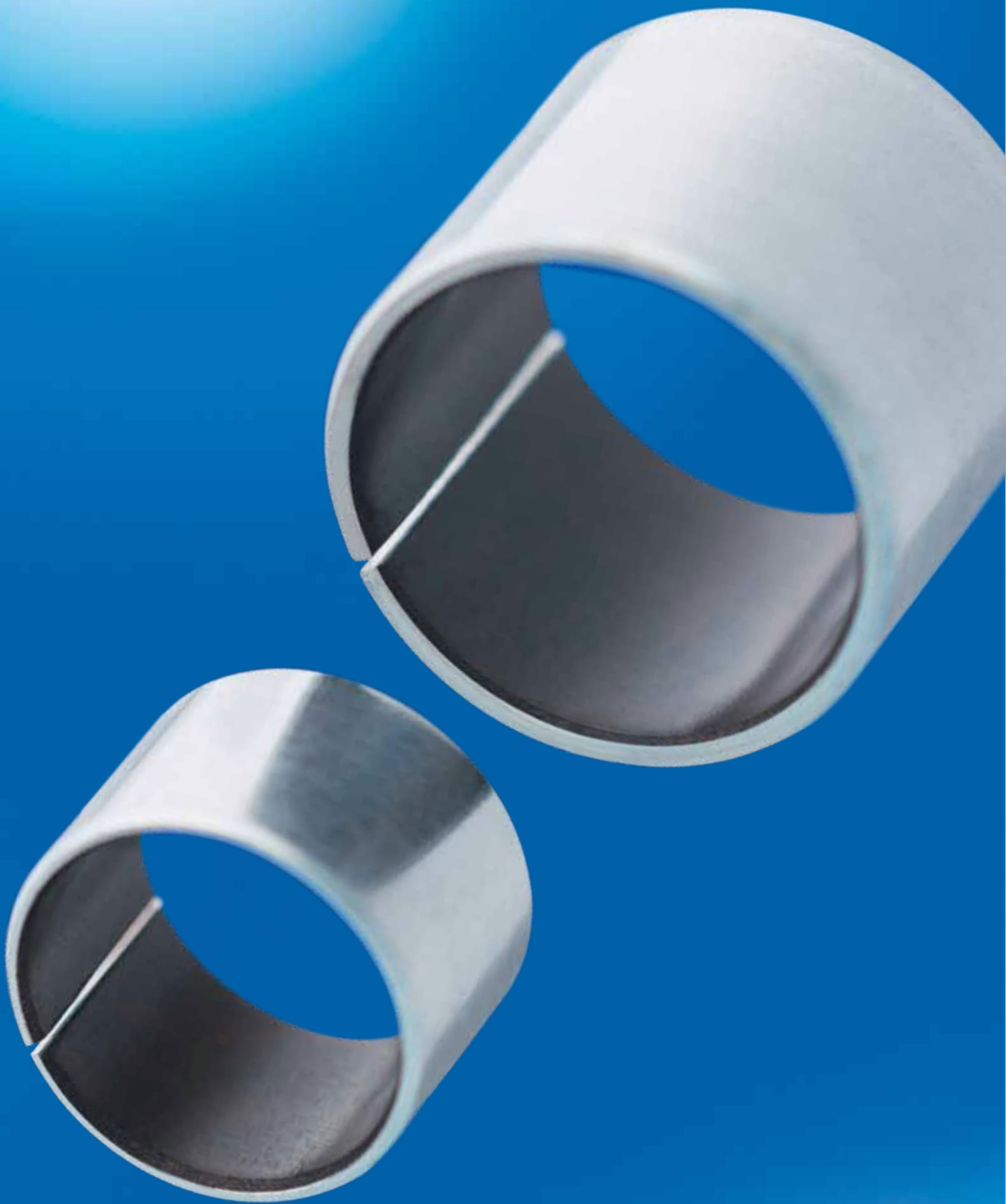

M-Liner Dry Friction Bearing

M-Liners are slotted, rolled bushings. They are made of zinc-plated sheet steel, laminated with a sliding coating made of PTFE. The sliding coating is a special PTFE compound with low friction coefficient and low wear.

The small thickness of the sliding coating (0.3 mm) means that M-Liners exhibit low heat expansion and good thermal conductivity, which in turn lowers the bearing temperature and increases bearing life. The steel jacket increases the load capacity of the bearing relative to all-plastic bearings.

The sliding material PTFE has an unusually high level of chemical resistance, due to the carbon-fluorine compounds. The chemical resistance of the M-Liner is mainly determined by the metal backing. Under the effects of media that corrode the steel jacket, all-plastic friction bearings made of Moldflon™ or Elringplast should be used.

M-Liner dry friction bearings are an alternative for all applications where classical lubricants, such as oil and greases, are not available.

Radial, axial, and oscillating motions are possible.

Application examples include

- Friction bearings in packaging machines, conveyor systems, office machines
- Armature bearings for electro-magnets

The bushings are particularly suitable for the following shaft materials

- Steel, ground and hardened
- Steel, bright drawn
- Stainless steels



Advantages

- Dry friction bearing with low friction and minimal wear
- No stick-slip effect
- Good thermal conductivity
- For high circumferential speeds

Product characteristics M-Liner (1)

Max. p·v value [N/mm ² · m/s]	0.67
Max. speed [m/s] (dry)	5
Max. permissible load [N/mm ²]	12
Max. application temperature [°C]	-140 to +180
Thermal expansion coefficient [1/K · 10 ⁻⁵]	6.8
Density [g/cm ³]	3.8
Water absorption [%]	0.09

Technical Details

p-v values

The limits of application of the M-Liner can be derived from the following characteristic curves. Depending on the sliding speed and the specific

load, each plotted characteristic curve indicates the maximum load under suitable conditions.

M-Liner

- The friction bearing with good heat dissipation
- For circumferential speeds of up to 5 m/s
- With high wear resistance
- For low-cost solutions

Permissible p-v values (2)

Test parameters: M-Liner with a 0.3 mm PTFE contact surface, steel shaft

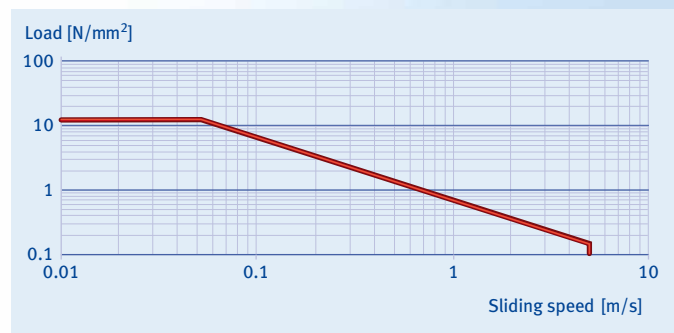

Wear with different contact surfaces

The material, hardness, and roughness of the contact surface all have a decisive influence on the wear behavior, and thus the service life, of the friction bearing.

Notes for designing the contact surface are described in the Design Information chapter on page 22.

Test parameters: t = 100 h, rotating, p-v = 0.623, D = 8 mm

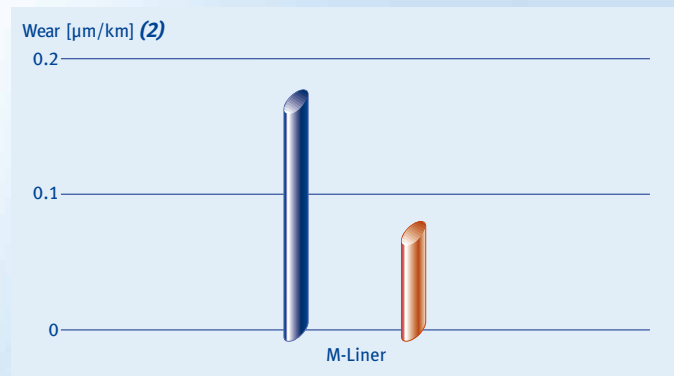

- X90CrMoV18, hardened and ground
- Hard-anodized aluminum

Maximum recommended load as a function of temperature

M-Liner dry friction bearings are generally usable in a temperature range from -140°C to +180°C in long-term operation. The compressive strength decreases with increasing temperature.

	Bearing temperature [°C] (2)				
	<30	30 – 60	60 – 100	100 – 140	140 – 180
Permissible bearing pressure P _{per} [N/mm ²]	12	10	7	4	1

Friction coefficient as a function of the sliding speed

The friction coefficient μ indicates the force that must be exerted in order to slide one body against another. A distinction is made between static and dynamic friction coefficients.

The friction coefficient varies, depending on the sliding pair and application parameters. The lower the friction coefficient, the less heat development by the friction bearing. This has a positive effect on wear behavior.

The friction of the M-Liner is determined exclusively by the PTFE sliding coating. It is minimal at high loads and low speed.

Test parameters: steel shaft, $p = 0.625 \text{ N/mm}^2$

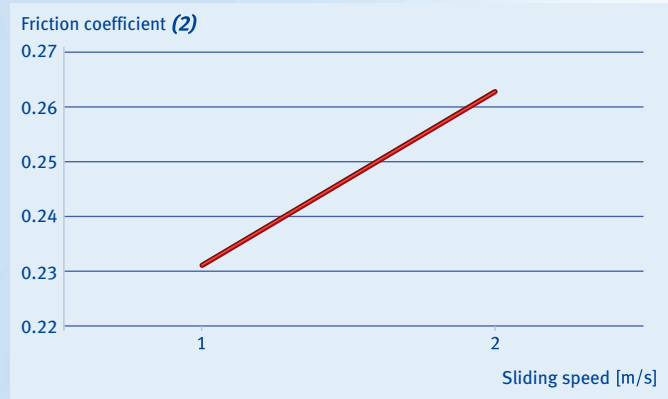

■ M-Liner



Standard dimensions

Special versions with sliding coatings that contain no non-ferrous metals, and/or non-standard dimensions, are available upon request.

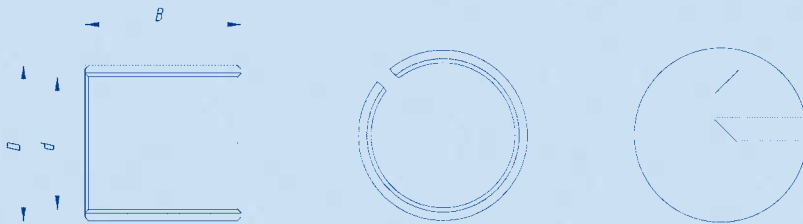

Width B Tolerance (0 / -0.25)									Dimension		Bearing clearance*	
8	10	12	15	20	25	30	40	50	d	D	Min.	Max.
ML0608									6	8	0.025	0.095
ML0808	ML0810								8	10	0.025	0.097
ML1008	ML1010	ML1012							10	12	0.025	0.099
		ML1212	ML1215						12	14	0.025	0.114
			ML1515						15	17	0.025	0.114
				ML1620					16	18	0.025	0.114
				ML1820					18	20	0.025	0.114
				ML2020	ML2025				20	23	0.025	0.129
				ML2220					22	25	0.025	0.129
				ML2520	ML2525	ML2530			25	28	0.025	0.129
						ML3030	ML3040		30	34	0.025	0.132
							ML4040		40	44	0.035	0.161
								ML5050	50	55	0.035	0.161

*Recommended bearing clearance in the assembled condition (recommended fit for hole H7 and shaft h7)



Elringplast Friction Bearings

Elringplast is a general term for self-lubricating, low-friction bearing materials based on PTFE. Elringplast friction bearings are an alternative for all applications where classical lubricants, such as oil and greases, are not available.

Due to the unusual characteristics of PTFE, Elringplast materials are optimal for conceiving maintenance-free dry friction bearings.

The compounds are characterized by high wear resistance and very good resistance to chemicals, over a wide range of usage temperatures.

Elringplast is available in three material variants, thus covering a wide range of applications.



Product characteristics (1)

	<i>Elringplast W2</i>	<i>Elringplast J</i>	<i>Elringplast LD</i>
Color	Black	Brown	Red
Max. p-v value [N/mm ² · m/s]	0.36	0.25	0.36
Max. speed [m/s] (dry)	2	2	2
Max. stat. surface pressure [N/mm ²]	7	5	7
Max. application temperature [°C]	-100 to +250	-100 to +250	-100 to +250
Thermal expansion coefficient (1/K · 10 ⁻⁵)	10.2	10.1	12.0
Density (g/cm ³)	2.08	1.94	2.28
Water absorption [%]	< 0.01	< 0.01	< 0.01

Advantages

- Low friction coefficient and high wear resistance
- Usage temperature from -100°C to +250°C
- Very good resistance to chemicals
- No degradation of shape or strength due to moisture
- No outgassing in vacuum
- Stable under oxidation and aging
- Low-cost due to simple bearing design and elimination of lubrication devices
- No contamination due to dripping lubricants
- Non-flammable; LOI >95

Dimensions per DIN ISO 3547-1 and special dimensions.

Please request your desired dimensions.

Technical Details

p-v values

The limits of application of the Elringplast friction bearings can be derived from the following characteristic curves. Depending on the sliding

speed and the specific load, each plotted characteristic curve indicates the maximum load under certain conditions.

Elringplast W2

- Material with a good friction coefficient for high circumferential speeds
- For low-cost solutions

Permissible p-v values (2)

Test parameters: friction bearing with 1 mm wall thickness, steel shaft

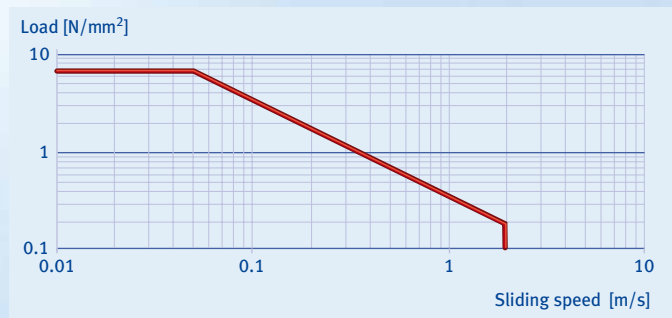

Elringplast J

- Material with very good wear resistance
- For high circumferential speeds
- Suitable for soft shafts

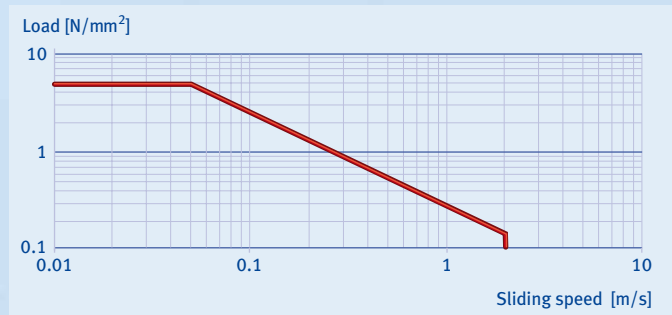

Elringplast LD

- Material with good wear resistance
- For high circumferential speeds
- For low-cost solutions



Wear with different contact surfaces

The material, hardness, and roughness of the contact surface all have a decisive influence on the wear behavior, and thus the service life, of the friction bearing.

Notes for designing the contact surface are described in the Design Information chapter on page 22.

Test parameters: $t = 100$ h, rotating, $p \cdot v = 0.623$, $D = 8$ mm

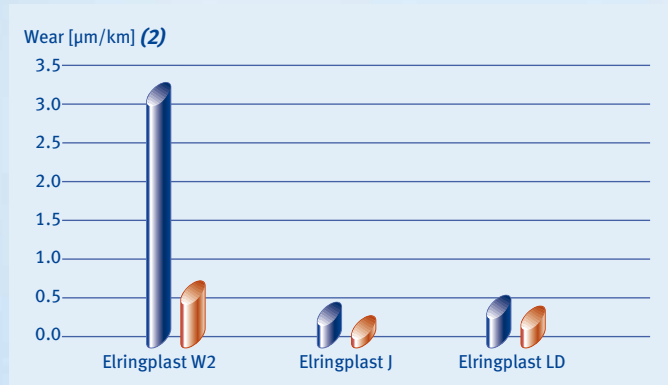

■ X90CrMoV18, hardened and ground
 ■ Hard-anodized aluminum



Maximum recommended load as a function of temperature

Elringplast friction bearings can generally be used in a temperature range from -100°C to $+250^{\circ}\text{C}$. The compressive strength decreases with increasing temperature.

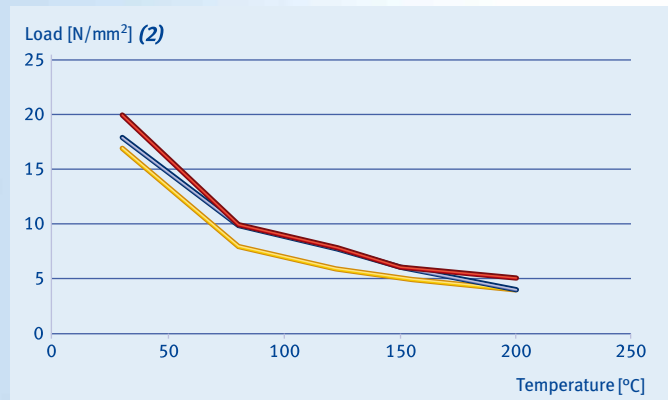

■ Elringplast W2 ■ Elringplast J ■ Elringplast LD

Friction coefficient as a function of the sliding speed

The friction coefficient μ indicates the force that must be exerted in order to slide one body against another. A distinction is made between static and dynamic friction coefficients.

The friction coefficient varies, depending on the sliding pair and application parameters. The lower the friction coefficient, the less heat development by the friction bearing. This has a positive effect on wear behavior.

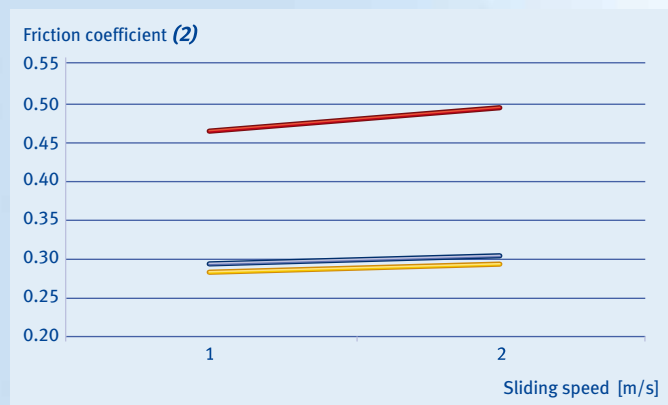

■ Elringplast W2 ■ Elringplast J ■ Elringplast LD



Application Examples

Elringplast friction bearings for industrial washing machines

- Very good chemical resistance
- Very good wear characteristics



Moldflon™ friction bearings for clutches

- For high loads
- Very good damping properties



Moldflon™ friction bearings for conveyor systems in the food industry

- For temperatures up to +250°C
- Conforms to food safety standards



Design Information

The function and lifespan of friction bearings made of Moldflon™ or PTFE is determined in part by design.

When selecting the correct friction bearing, the following should be taken into consideration:

- Load and speed
- Roughness of the contact material
- Tolerance ranges
- Thermal expansion

Roughness of the contact material

The lubricant effect of the ElringKlinger friction bearing is caused by material transfer. Run-in wear is necessary in order to build up a lubricant layer on the contact part.

This process depends on the roughness of the contact partner. The recommended roughness is Ra = 0.2 to 0.4 µm. Above Ra = 0.8 µm, the wear increases significantly.

Tolerance ranges

For ElringKlinger friction bearings, the recommended fit is h6 for the shaft and H7 for the hole.

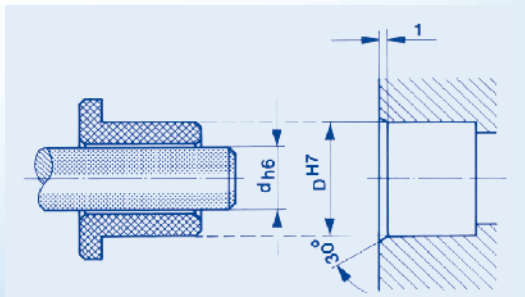

Load and speed

ElringKlinger friction bearings are selected according to the p-v value—a factor consisting of the load per sliding surface times speed.

The p-v value depends on the temperature. The permissible p-v value drops as the temperature increases.

$$p \cdot v = \frac{\text{Load [N]}}{\text{Sliding surface area [mm}^2]} \cdot \text{speed [m/s]}$$

$$p = \text{force } F \text{ acting on the projected friction bearing surface (shaft diameter } d \cdot \text{ bearing width } B).$$

$$v = \text{sliding speed, circumferential speed of the shaft}$$

$$v = \frac{\text{rotary speed } n \text{ [1/min]} \cdot \text{shaft diameter } d \text{ [mm]} \cdot \pi}{1,000 \cdot 60}$$

$$p \cdot v [\text{N/mm}^2 \cdot \text{m/s}] = \frac{F[\text{N}] \cdot n[\text{1/min}] \cdot d \text{ [mm]} \cdot \pi}{d[\text{mm}] \cdot B[\text{mm}] \cdot 1,000 \cdot 60}$$

Assembling the bearings

ElringKlinger friction bearings must be pressed in place with a flat punch in order to prevent damage.

Care must be taken that the insertion holes for the bearings are clean and do not have any sharp edges. A chamfer should be provided in the pressing direction.

For operating temperatures up to 90°C, no additional retention is required for the bearing. Only at high or severely variable operating temperatures should the bearing be additionally secured.

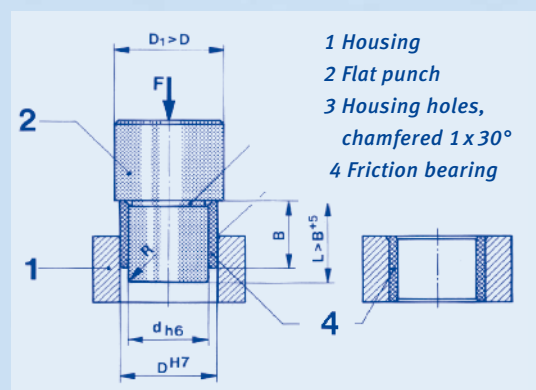

Technical Questionnaire

Please complete and fax to:
+49 7142 583-200



1. Brief description of the application (sketch)

2. Dimensions

Shaft diameter (mm): _____

Bearing width (mm): _____

Bearing wall thickness (mm): _____

Flange diameter (mm): _____

Flange thickness (mm): _____

3. Mating part

Diameter with tolerance: _____

Material: _____

Mean roughness Ra (µm): _____

Hardness (HRC): _____

4. Housing

Diameter with tolerance: _____

Material: _____

5. Operating conditions

Bearing load (N): _____

Sliding speed (m/s): _____

Type of motion:

Rotating (rpm): _____

Pivoting angle (°): _____

Linear: Stroke length (mm): _____

Frequency (1/min): _____

Lubrication (dry, oil,
grease, or water): _____

Ambient temperature (°C): _____

Environmental media
(e.g., acids, lye, etc.): _____

6. Special requirements

e.g., certifications, friction,
service life, etc.: _____

Intermittent duty: _____

Ratio of idle to running
time: _____

7. Requirements

One-time (pieces): _____

Monthly (pieces): _____

Annually (pieces): _____

Company (address)

Contact person

Phone

Fax

E-Mail

Put Our Plastics Know-how to the Test.

The information provided in this brochure, based upon many years' experience and knowledge, does not claim completeness. No liability is assumed for damage claims on the basis of this information. All parts must be installed by trained and specialized staff. Product range and technical specifications subject to modification. No liability assumed for errata.



ElringKlinger Kunststofftechnik GmbH | Etzelstraße 10 | D-74321 Bietigheim-Bissingen
Phone +49 7142 583-0 | Fax +49 7142 583-200
Division Venus | Badenbergsstraße 15 | D-89520 Heidenheim
Phone +49 7321 9641-0 | Fax +49 7321 9641-50

ekt-info@elringklinger.com | www.elringklinger-kunststoff.de



DQS-certified according to ISO/TS 16949 (Reg. no. 002504 TS/Q1/003) | DIN EN ISO 14001 (Reg. no. 002504 UM)